



NEW CLASSICISTS  
WILLIAM T. BAKER

William T. Baker's work is inspired by the bounty of classical architecture found in the grand homes of the southern United States, particularly Georgia. The hallmarks of his architecture are his extraordinary attention to the finer details of craftsmanship and construction, and his keen eye for scale and proportion.

Throughout the pages of this richly illustrated book, we meet the families who have entrusted him with their dreams and visions and whose trust has been rewarded with classically inspired homes of grace and beauty.

The twenty-eight projects presented in this volume encapsulate the first two decades of William T. Baker's career and give the reader a glimpse into the lives of these modern American families. Blending seamlessly into historic neighborhoods, these new 'old houses' are outstanding achievements in timeless, permanent architecture that resists modern shortcuts and easy solutions.

An insightful introduction by Atlanta historian, Beverly Means DuBose, III contributes to a deeper understanding of the history of classical architecture in America and the culture that has produced some of the world's great residential architecture. Says Mr DuBose, 'Few possess the talent to be sensitive to the desires of the client while producing a classical design that is livable, functional, and a visual delight.'

William T. Baker is one of America's talented designers who is at the forefront of the renewed interest in classicism. His work is contributing greatly to some of the most esthetically pleasing residences being built in the United States today.



# NEW CLASSICISTS

WILLIAM T. BAKER





*Hudson House, Atlanta, Georgia*

728  
H76

# NEW CLASSICISTS

WILLIAM T. BAKER

INTRODUCTION BY  
BEVERLY MEANS DUBOSE, III

PRINCIPAL PHOTOGRAPHY BY  
JAMES R. LOCKHART

*scan: The Stainless Steel Cat*









*Tice House, Dalton, Georgia*

*Dedicated to my wife, Carolyn,  
and to my daughters, Katherine, Sarah, and Emily.*

*And to my mother, Martha, and the memory of  
my father, William T. Baker, Sr. (1907–1994).*

First reprint in 2005

The Images Publishing Group Reference Number: 613

Published in Australia in 2004 by

The Images Publishing Group Pty Ltd

ABN 89 059 734 431

6 Bastow Place, Mulgrave, Victoria, 3170, Australia

Telephone: +61 3 9561 5544 Facsimile: +61 3 9561 4860

Email: [books@images.com.au](mailto:books@images.com.au)

Website: [www.imagespublishing.com](http://www.imagespublishing.com)

Copyright © The Images Publishing Group Pty Ltd 2004

The Images Publishing Group Reference Number: 564

All rights reserved. Apart from any fair dealing for the purposes of private study, research, criticism or review as permitted under the Copyright Act, no part of this publication may be reproduced, stored in a retrieval system or transmitted in any form by any means, electronic, mechanical, photocopying, recording or otherwise, without the written permission of the publisher.

National Library of Australia

Cataloguing-in-Publication entry:

William T. Baker and Associates.

ISBN 1 920744 57 6.

1. William T. Baker and Associates. 2. Architects – United States.

3. Architecture, Domestic – United States. 4. Architect-designed houses – United States.

(Series: New Classicists).

728.370973

Designed by The Graphic Image Studio Pty Ltd, Mulgrave, Australia

Website: [www.tgis.com.au](http://www.tgis.com.au)

Film by Mission Productions Limited

Printed by Everbest Printing Co. Ltd, in Hong Kong/China

IMAGES has included on its website a page for special notices in relation to this and its other publications.  
Please visit this site: [www.imagespublishing.com](http://www.imagespublishing.com)

**Additional photography credits:**

Mikhail Boutchine: 230–233, 235, 236, 238–243

Emily Jenkins Followill: 14

Debra Whitlaw Lewcllyn: 63

Judith Schindler: 157

Dave Shafer: 68

Robert Thiem: 25, 28, 31, 32, 36–37, 49, 59, 151–156

*Following pages:*

*Kane House, Atlanta, Georgia*



# CONTENTS

Introduction	
<i>by Beverly Means DuRose, III</i>	10
Classically Inspired	
<i>A Personal Story</i>	14
<b>The Krone House</b>	24
The Dempsey House	38
The Baldwin House	48
The Slone House "Arcadia"	58
The Noonan House	68
The Anthony House	86
The Gregory House	104
The Mills House	116
The Johnson Homeplace	126
The Smidt House	140
The Schindler House	148
The Faulk House	158
The Ledbetter House	168
The Loudermilk House	176
The Siegel House	190
The LaBricla House	200
The Allen House	208
The Himot House	220
The Burfill House	230
The Clare House	244
The Rosener House	256
The Stevens House	266
The DeGuardiola House	276
The Ahmad House	292
The Berry House	302
The Winston	314
The Crescent at Post Riverside	318
The Borphese	324











# INTRODUCTION

Architecture, more than any branch of the humanities, more than art, literature or music, has the greatest impact on our daily existence. We live, work, shop, and often spend our leisure time in the products of the discipline. These creations of humanity provide a constant visual impact and a large portion of the 'fabric of time' that gives us a sense of our place of being.

No other country has the variety of styles of domestic architecture found in America. The early settlers brought with them the simpler styles of their countries of origin and adapted them to the climate and building materials available in the regions they settled. The earliest architectural styles in North America came predominantly from England and to a lesser extent Holland, France and Spain.

Almost all of the commercial ties of the original 13 colonies were with England. The styles and design then in vogue in the mother country were eventually transferred to the colonies, usually modified to conform to the lesser economic conditions as they existed here. Therefore, 'Colonial Architecture', as it is now called, was influenced by the works of Inigo Jones who, in turn, was influenced by the 16th-century Italian architect, Andrea Palladio and his *Four Books of Architecture*. He was followed closely by Christopher Wren, who is probably best known for his design of St. Paul's Cathedral, constructed after the great fire of London in 1666. In this country, he designed the earliest building for the College of William and Mary in Williamsburg, Virginia.

This Palladian influence was carried into the period of Georgian architecture. This period was named for the Georges of the House of Hanover, who ruled England for more than 120 years following the death in 1714 of the last Stuart monarch, Queen Anne. Architectural design books assisted greatly in creating the pervasiveness of this Palladian influence. One of these was the *Book of Architecture* by James Gibbs, published in London in 1728. These books provided not only engraved plates of Palladian design but the proportions that form the basis of that movement. Thomas Chippendale's *The Gentlemen and Cabinet-maker's Director* published in 1754 is probably the best example of the influence these published works had in their respective fields of design.

When the first U.S. census was taken in 1790, it was a rural and agrarian country of four million, which included 600,000 slaves. Influences from England were still strong, but native talent, such as Charles Bullfinch, who graduated from Harvard in 1781, was beginning to develop. He sailed for Europe in 1787 and, under the tutelage of Thomas Jefferson, who was at that time Ambassador to the Court of Louis XVI, traveled to southern France and Italy.

At that time, the Palladian influence was still strong but it was modified by the neo-classicism practised by brothers Robert and James Adams who, in turn, were influenced by the recent discoveries at Pompeii. The resulting style in America became known as Federal, named for the Federalist Party headed by John Adams of Massachusetts. Charles Bullfinch became the chief practitioner of the new style and is probably best known for his design of the 'New State House' on the Boston Commons.

Once again, design books played a significant role in disseminating the Federal style. These are best illustrated by Asher Benjamin's *The Country Builder's Assistant* (1797) and the *American Builder's Companion* (1806). The Federal style dominated the architecture of New England.

The selection in 1790 of the site on the Potomac River in Maryland for the nation's new capital created a stage upon which this fledgling country could create its identity. The first two buildings to be built were the President's house (which had to be painted white to cover the smoke damage from the British, having burned it in the War of 1812) and the Capitol. The building as we know it today is largely the work of the British trained architect, Benjamin Henry Latrobe, even though he was not selected as the original designer of the Capitol. Latrobe, a protégé of Thomas Jefferson, once wrote to him that 'My principles of good taste are rigid in Grecian architecture.'

In his book *Classic America*, Wendell Garrett stated 'The Greek revival was the first pervasive and self-conscious nationalistic movement in American architecture.' In the perception of many, this was the style most associated with

Southern domestic architecture. As this style emerged in the first quarter of the 19th century, the plantations of the South were being created. These grand homes reaped the benefits resulting from Ely Whitney's invention of the cotton gin in 1794 and the economic fortunes it created. The cotton gin made possible the separation of the seeds from the fibers thereby making short staple cotton an economically viable crop. This invention encouraged the spread of cotton cultivation throughout the deep South and once again set the region on the course of a single-crop economy based on slave labor. The combination of the availability of cotton with the increased capacity and efficiency of the looms, aided by the advent of the steam engine, led to a reduction in the price of cotton cloth and greatly increased its demand. The South exported 3,000 bales of cotton in 1790, but by 1860, this export had risen to four million bales, which supplied the mills of England and France. The New England mills were also supplied by southern cotton. This provided the new plantations that spread across the region with money to spend on this new national style of architecture.

What became the city of Atlanta began in 1837 as the starting point of the state-built Western and Atlantic Railroad that would eventually run to Chattanooga. It wasn't until 1845 that the city was actually named 'Atlanta' (the female version of Atlantic). By 1860, Atlanta had become a town of 10,000 and was the transportation hub of the region with three other rail lines from Columbus, Macon and Augusta joining here. Atlanta can truly be called a 'child of the railroads.' It was one of the first major cities not to be constructed on a navigable waterway.

At 1,000 feet above sea level, amid the rolling hills of the Piedmont, Atlanta was never the center of plantation culture and its massive Greek Revival architecture. During the American Civil War, Atlanta was the focus of General William T. Sherman's campaign in the spring and summer of 1864, ending in its capture in September of that year. The Confederate army began the damage by destroying its ammunition train as it abandoned the city. Sherman completed the task in November as he left the city on his infamous 'march to the sea.' This destruction, coupled with the city's disregard for preservation, left Atlanta with only five structures that pre-date 1864.

Due to Atlanta's strategic position as a transportation hub, the state capital was moved there from Milledgeville in 1868. Growth of the area has not ceased since. Virtually every residential neighborhood and structure is a product of the 20th century. Like many cities, Atlanta exhibits many styles of architecture that dominated different periods—the late Victorian, the bungalow, the ranch house with its picture window, to the present 'European Traditional' (whatever that connotes!).

Despite the evolution in architectural design that produced Frank Lloyd Wright's Falling Waters in 1935 and Phillip Johnson's Glass House in 1949, the taste exhibited in the grand homes of Atlanta during the past 80 years has never strayed from the classic styles of English Tudor, Georgian, Italianate, Federal, Regency and Greek Revival.

Atlanta has been home to several exceptional classical architects and designers whose works span the first three quarters of the 20th century. The first of these was Neel Reid (1885–1926), who set the standard for fine classical design in his residential and commercial work throughout the city. His associate, Philip Trammell Shutze (1890–1982), introduced Atlanta to the vigorous forms of Italianate and the reserved elegance of English Regency architecture. One of his most important works was the Inman family's home, Swan House (1927), which boldly expresses his mastery of the Italianate.

There were three others who were associates of Neel Reid and/or Phillip Shutze and went on to form their own firms. The first of these was Lewis Edmund 'Buck' Crook (1898–1967), whose work emphasizes Jeffersonian and southern classicism. He was followed by James Means (1904–1979), who graced the city with a number of fine residences in the American Colonial and French Provincial vernacular. The third member of this group was Edward Vason Jones (1909–1980) who moved to Albany, Georgia following World War II and continued the tradition of neo-classicism. He achieved a national reputation for his work and was invited to be the consulting architect for the Diplomatic Reception Rooms at the United States Department of State as well as for the White House.

By 1980, the era of these classical designers had ended and, unfortunately, the next generation had not yet begun its practice. It appeared that the use of classicism in residential design might end at this point. However, in a few years, a new generation emerged with a keen understanding and admiration for classical architecture. Bill Baker was among the first of this new group.

Having known and worked with Bill Baker for over 15 years, I very much believe he follows in the footsteps of the talented, dedicated men who preceded him. Bill's work has a classical appearance, that is, classical in the emerging meaning of the word: 'attention to form with the general effect of regularity, simplicity, balance, proportion and controlled emotion.' I have seen Bill design homes in most of the classic 'architectural styles,' inevitably remaining true to the particular style selected. His design always has a grace and harmony created by its balance and proportions. It is no easy task to make the interior conform, not just to the exterior proportions, but to the demands of a modern lifestyle that is far removed from the lifestyle that existed when these classic designs were first created.

Few possess the talent to be sensitive to the desires of the client while producing a classical design that is livable, functional and a visual delight. Yet, Bill is one of those talented few. He has designed homes for me for many years, allowing me to experience firsthand his tact and patience. Bill is very much a part of Atlanta's love of the classical and his work contributes greatly to giving its rolling hills some of the most esthetically pleasing residential areas in the country. Because of his design talents, Bill's work has gained a much broader following than just in Atlanta and now can be found throughout the nation.

I hope you enjoy getting to know Bill through his works, and that you can visualize the design process of these homes as you turn the pages of this delightful book.

*Beverly Means DuBose, III*  
*Atlanta, Georgia*  
*September, 2004*



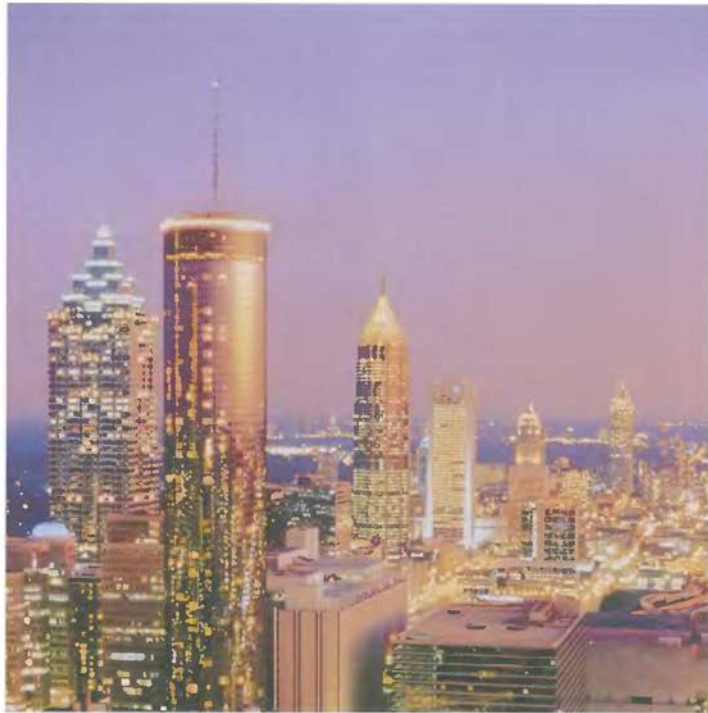

*Atlanta, Georgia, 2004*



# CLASSICALLY INSPIRED

## A personal story

In retrospect, my childhood was very rich visually. My father was a nationally acclaimed furniture designer, and I would watch him draw his designs on thick ivory-colored paper at his drafting table. Sometimes when he would let me, I'd climb up onto the tall wooden stool next to his chair and trace around his French curve templates or carefully inscribe circles with a compass. I developed a love for drawing and an eye for detail at an early age.

My father taught me how to draw cubes and rectangles in three dimensions. In fact, I was the only child in my kindergarten class who knew how to draw objects in perspective! By the time I entered second grade, I was able to sketch a farmyard scene and show the barn in correct perspective with its shadows.

We lived in a beautiful Georgian-style house that my father had built in Nashville, Tennessee. It was full of details that caught the attention of my young eyes. Whether it was the graceful curved staircase in our foyer or the dentils in the paneled library, the unique details of this house always provided me with something of interest to contemplate.

My hometown of Nashville was filled with important architecture. My parents and I visited Centennial Park, where I climbed the oversized steps of its replica of the Athenian Parthenon. I was impressed by its huge bronze doors, painted friezes, classical statuary and the grandeur of Greek architecture. It was a most memorable introduction to classical architecture.

When I was a teenager, I had the pleasure of visiting Cheekwood, one of America's great treasure houses. Built in 1929, it was like a grand dame sitting high on a hill, overlooking the rolling hills and meadows of the surrounding countryside. My interest in this house consumed me for years. It was so large, so exquisitely designed, and so perfect in its setting and gardens that I found myself exploring it whenever I could.

I eventually served as a guide for the Nashville Public School's Christmas tour of Cheekwood. I took great delight in opening the children's eyes to the things that made the house so special. I wanted them to leave with more than just the memory of the seasonal decorations. I wanted them to recognize an egg-and-dart molding or a Palladian window. I knew firsthand the excitement that could come with an early love of exceptional architecture.

I was also significantly influenced by two books, *American Vignola* by William Ware and Edith Wharton's *The Decoration of Houses*. These two books opened the mysteries of classical architecture, proportions, and scale to me. I referred to

these books over the years and through them came to understand the principles of classicism and to develop a discerning eye for what is, or is not, in 'good taste.'

In 1975, I enrolled at Auburn University, planning to major in architecture after my second year. This seemed to be a good plan given my lifelong love of architecture and the artistic talent I had demonstrated. However, I was disappointed to find that the curriculum had largely abandoned its classical foundations and had embarked on a new aesthetic direction that didn't appeal to me.

Furthermore, during my sophomore year, many of the graduating architecture students began sharing stories of firms laying off architects rather than hiring new ones. The country was still reeling from the effects of the Arab oil embargo, inflation was rampant, and construction-related businesses had few entry-level openings. So, I declared a major in business finance, thinking this would result in better job prospects.

After graduating in 1979, I found that the prolonged recession had affected the job market for business graduates, and my best efforts were for naught. I was in exactly the situation I had hoped to avoid! I accepted a job selling insurance but this company soon went out of business. My career seemed to be off-track, and I searched for a new direction.

During this time, I received an unexpected and much-needed word of encouragement. I casually mentioned to someone that if these were the best days of my life, as the old saying goes, then I was in trouble. This wise person

*His childhood home*





## Cheekwood



responded, "The early years of a young person's life are not the best years, but rather the most fun. The *best* days are still ahead." I held onto these words as I wondered what the future held in store for me.

Like many of my peers during this time, I applied to a graduate school of business to earn a master's in business administration. Surely with an MBA from a good school, I would have success securing a better job. But, shortly after applying to Vanderbilt University in Nashville, a chance meeting completely changed my plans.

On a whim, I went to see an executive recruiter to find out which major within the MBA program was most in demand. He confirmed my strategy of pursuing a graduate degree, but suggested I attend Emory University in Atlanta. He said registration for the fall class was still open and that I should apply immediately. This short conversation would impact the course of my life in a way I could never have imagined at the time.

Moving to a large city where I had no family contacts and I knew no one was a daunting task. But I had the hope of a new beginning and new opportunities. My spirits were high as I entered the fall class of Emory's Graduate School of Business in 1980.

After graduating two years later, I obtained that all-important job for which I had worked so hard. As an in-house consultant for Trust Company Bank, I was engaged in projects for senior executives that allowed me to see many sides of the banking business. I was promoted to officer of the bank after one year, but something wasn't right. My first love was still architecture, and deep inside I knew that I was wasting my real talent. I was restless.

One morning in the summer of 1984, the major Atlanta newspaper ran an article about a local real estate developer, Martin Marchman. He was making a name for himself by building million-dollar speculative homes. This was the first time the

city had seen anything like this on such a large scale. Job growth among Atlanta's corporate community was strong, and Marchman was building new homes to meet the needs of the Fortune 500 executives moving to Atlanta. Suddenly, I had an idea! Why not contact Marchman to inquire if I could work for him as a business consultant? At least that way I could be around architecture.

Marchman suggested that I might work in his in-house architecture department, which was run by Steven Fuller. After meeting with him, Fuller decided the best fit would be for me to administrate the architectural control committees for Marchman's numerous subdivisions. I was happy to accept the job and began to learn all I could about reading working drawings and the construction of houses.

I could not have asked for a better education than the one I received in my daily conversations with builders and tradesmen. My job was to confirm that the houses were being built according to the approved plans. When I would question why a particular detail didn't look like the approved plan, the builder or carpenter would review the drawings with me, and in some cases, thank me for my keen eye. In a very short period of time, I learned a great deal about construction drawings and developed a respect for the people in the field who are responsible for turning those drawings into the reality of a finished home.

Back in the office, I got to use my drafting skills. I received the necessary critiquing to help me develop good lettering and line quality. Within a couple of weeks, I was able to draw exterior façades and make revisions to floor plans. I learned the fundamentals of dimensioning and standard sizes for doors, windows and plumbing fixtures. I enjoyed drafting and practised in the evenings to further develop my skills.

By the end of the first year, I moved on to begin a consulting business administrating architectural control committees for developers in Cobb County, Georgia. The builders and real estate agents in these subdivisions sought my opinion about ways to improve the layout and overall aesthetics of their plans. My suggestions were well received, and I was asked to revise kitchens, bathrooms and exterior façades.

Wishing to gain even more knowledge, I studied Edward Muller's classic textbook *Reading Architectural Working Drawings*, memorizing the terminology and construction standards. In addition, I retained the services of a structural engineer to help me properly detail my foundation and wall sections.

My reputation grew, and within the year, I was drawing complete home plans. These early houses were relatively simple, but they were perfect for my level of experience. The knowledge I learned from the builders, combined with my self-study and inherent abilities, allowed me to succeed. I remain indebted to those first builders who gave me the chance to prove myself.

Settling into my career, I was at peace. I studied books on the great homes of the world and explored Atlanta's older neighborhoods to find new inspiration. I worked in my small condominium and eventually filled the closets with rolls of drawings in boxes. In those early years, my typical workdays were long, but I was



doing something that I truly enjoyed. I knew from experience how rare that was. Plus, I was creating something of beauty, usefulness, and permanence while using my love of architecture and natural talents. I had finally found my place.

I married in 1990 and purchased a charming cottage that was our first home. I enclosed a side porch to serve as my office and continued to work from home. As my business grew, I hired associates who also worked from their homes. We communicated by telephone and fax throughout the day. Because we didn't spend time commuting to work and encountered few of the distractions of office settings, we had a productivity level that larger firms couldn't match. It was a productive, efficient arrangement—so much so that I continue to work this way today.

At the same time, I continued to administrate architectural control committees and began work in the community of Chatsworth, which is located in the affluent northwest Atlanta area known as Buckhead. Some of the homeowners and builders there hired me to design their homes. In turn, these homes caught the attention of the Atlanta real estate community, and realtors began mentioning my name to their clients. My work in Buckhead began to expand exponentially.

One day, I received a phone call from a builder who had purchased a house on Tuxedo Road, one of the most prestigious streets in Buckhead. He had demolished the existing house and was planning to build an expensive speculative home. Although he had already poured the foundation, he had changed his mind and wanted to start over with a new design. "What I really want," he said, "is to build a grand Georgian house with hand-carved limestone. Can you work with me?" Of course I said yes, and the result is one of my best-known houses in Atlanta.

Designing this house was not nearly as big a challenge as finding the craftsmen to carve and install the limestone. Nothing like it had been built in Atlanta since the 1920s. In addition to the stonework, the house had elaborate interior finishes that required special talent to execute. After much research, the team was assembled and the house completed. It was purchased by Dr and Mrs Howard Krone.

Unbeknownst to me, the Indiana Limestone Institute had been following the progress of this house since I first contacted its leadership to find craftsmen for the stonework. The Institute had submitted the house to Henry Hope Reed in New York City to be considered for the annual *Arthur Ross Award in Architecture* given by Classical America. Imagine my surprise when I received a call from Mr. Reed that I had been selected to receive the award for 1993! Receiving this award put me in a select group of nationally recognized designers and architects, several of whom were from Georgia. It was a great honor.

As the years progressed, key players in the Atlanta real estate community recognized my talent. Dick Goodsell and his brother Bob hired me to design houses for their communities of Baker's Farm, North Valley and Drummond Point. Joe Dewberry and Tommy Sweet hired me to design the entire community of Highgrove in Vinings. They were followed by Tom Turrentine at Carter's Grove and Bo DuBose at Paces Ferry 2000, also located in Vinings. Will Stoltz and Alan McRae hired me for their community of Brookhaven Registry, and Fritz Rybert used my design services for homes in the Farm Brook and Stone Brook communities in northeast Atlanta.

Further recognition came when Home and Garden Television's award-winning show *Before and After*, requested that I submit some of my remodeling projects for consideration. As one of the network's top-rated shows, it proved to be an effective way to give my work national exposure. *Before and After* presented seven of my projects—all dramatic transformations of ugly-duckling houses into neighborhood showpieces. Some of these projects are among my proudest work, as each presented special challenges not found in new construction.

As my family grew, we purchased an historic Buckhead house. The large English Regency-style home, with its old brick and white columns, was built in 1936 by the descendants of Henry Grady, Atlanta's 'voice of the New South'. It was Grady, editor of the Atlanta newspaper, who helped convince northern industrialists to invest in the reconstruction of the South after the Civil War.

This house has served me well. My office is located in a beautiful glass-enclosed side porch that serves as a cheerful sunlit studio. At night, I can see the lighted tower of Saint Philip's Cathedral glowing in the distance through my office window. It is an inspirational setting in which to work.

The journey I have traveled to reach this point in my career has been an amazing one. When I moved to Atlanta, I could never have imagined that I would one day impact the built fabric of this city's already rich architectural history. I hope this book will serve as a document of the very special times that I shared with my clients, times that afforded me not only a place in their own personal histories, but in Atlanta's as well.

CLASSICAL AMERICA  
PRESENTS  
THE ARTHUR ROSS AWARD  
TO  
WILLIAM T. BAKER  
For his splendid residence in the classical manner  
built in Atlanta.



APRIL 26TH  
NEW YORK CITY  
1993



*Bugg House, Atlanta, Georgia*



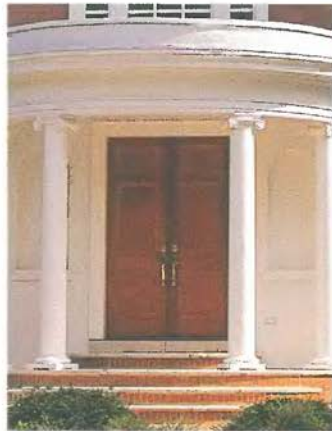

WELCOME



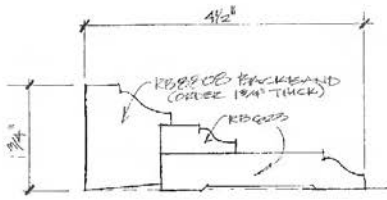

(A) DOOR CASING FULL

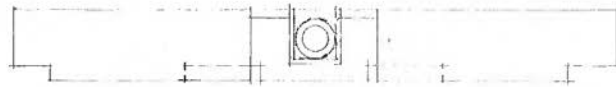

PLAN VIEW OF HOOD

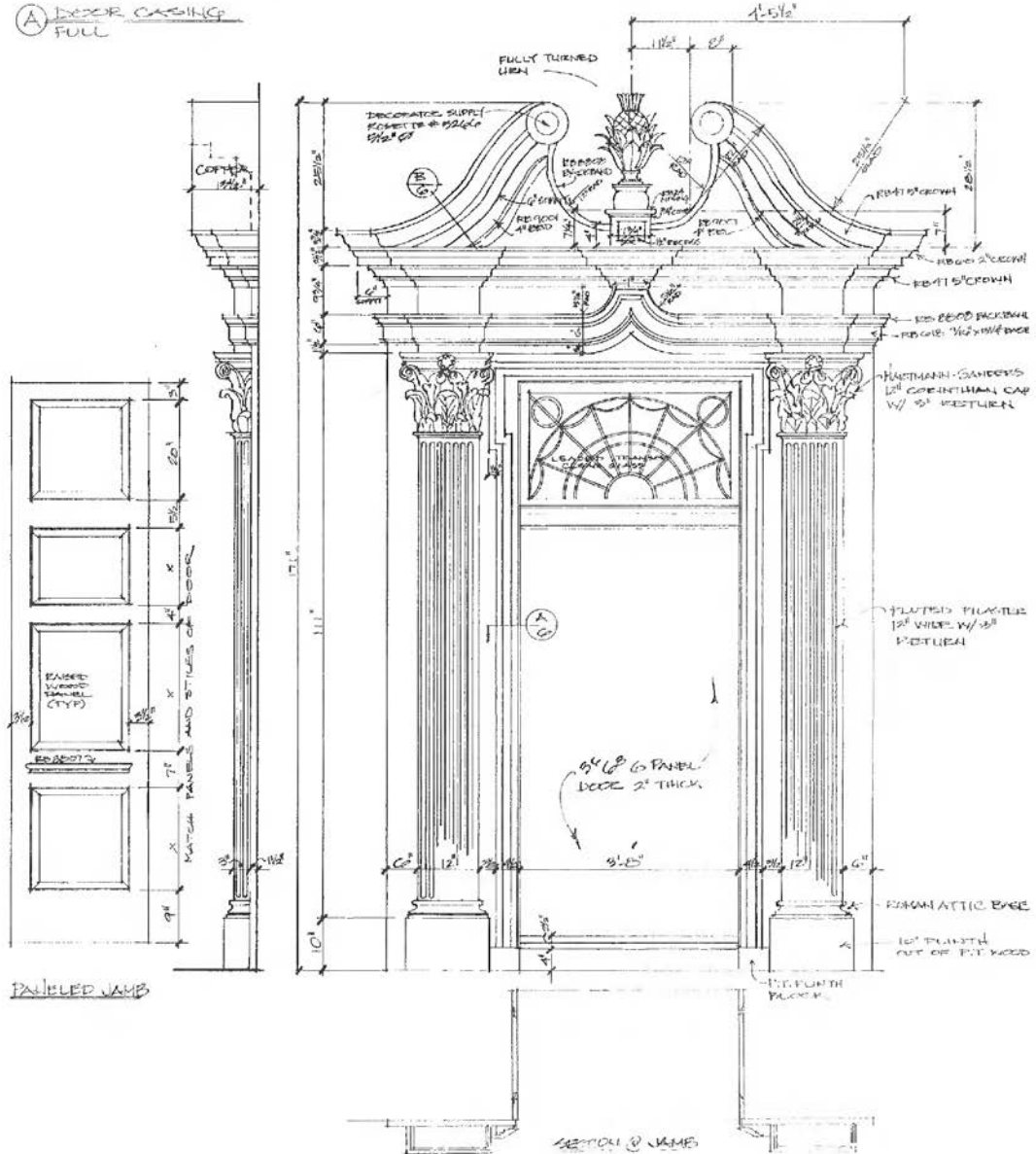

PANELED JAMB

SECTION @ JAMBS



*D'Houlier House,  
Atlanta, Georgia*

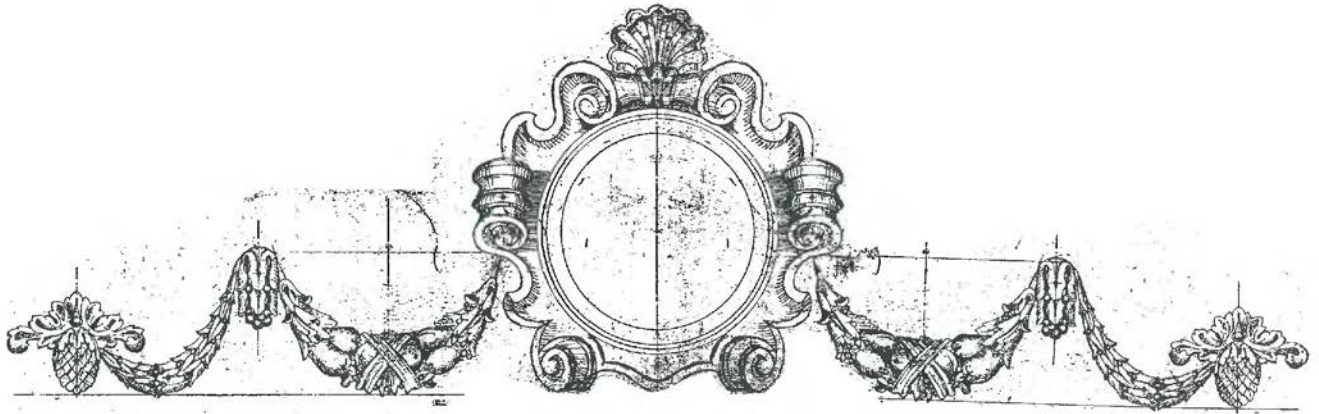

*Hemon House, Dalton, Georgia*





*McIntire House, Dalton, Georgia*

# THE KRONE HOUSE

Atlanta, Georgia, 1989–1990

*Mattei-Miller, Contractor*

*Interiors by Stan Topol & Associates*

When the Krones first looked at this house, it was a partially finished shell—only the beginning of the stone work had been installed. It took vision to see the house's enormous potential. "When we first saw the house, we immediately fell in love with the floor plan," says Mrs Krone. "The design for the stonework was also very exciting. We realized how special the house was going to be." The home would soon have the distinction of being one of Bill Baker's first signature homes and an architectural landmark for the city and Tuxedo Road. For his work on this house, Baker received the coveted *Arthur Ross Award* in New York City in 1993, Classical America's annual award recognizing excellence in classical design.

Drawing upon the rich architectural heritage of Neel Reid, an early 20th-century Atlanta architect, Mr Baker designed the house to incorporate hand-carved limestone in a classical manner similar to Reid's work from 60 years earlier.

"Because nothing like this had been built in several generations, we found ourselves almost re-creating a lost art form. I had to research the material and locate the artisans who were capable of executing my design. We wanted the work to authentically reflect classical architectural standards," says Baker.

"Classicism is, of course, timeless and stone has always been the primary medium for classical architecture. I was excited to be a part of keeping this craft alive for our generation."

In addition to its elegant design, the Krone House features all modern amenities including a spacious floor plan, a wine cellar, and a racquetball court. The residence pays tribute to classicism at its best while accommodating the needs and lifestyle of a contemporary southern family.











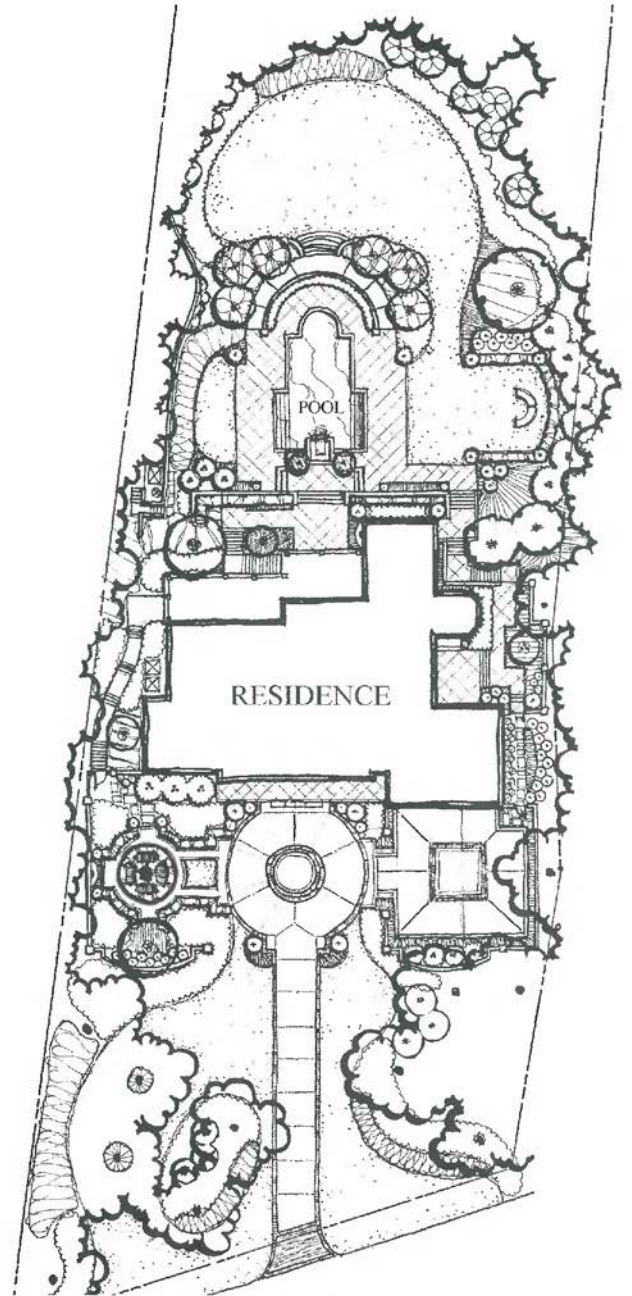

LAND PLUS ASSOCIATES LTD.  
LANDSCAPE ARCHITECTS







First Floor

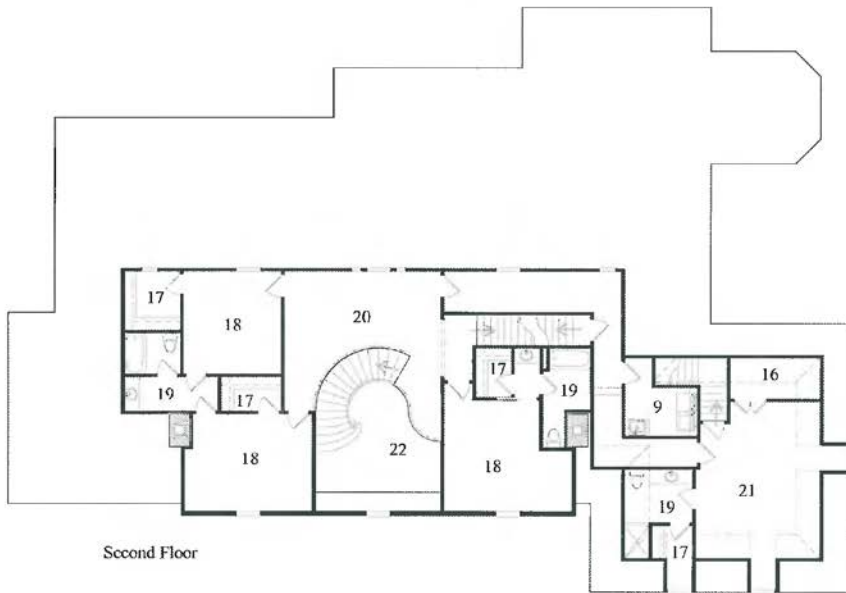

Second Floor

- |               |                |                   |               |                  |
|---------------|----------------|-------------------|---------------|------------------|
| 1 Foyer       | 6 Kitchen      | 11 Garage         | 16 Storage    | 21 Au-Pair Suite |
| 2 Living Room | 7 Breakfast    | 12 Master Suite   | 17 Closet     | 22 Open to Below |
| 3 Dining Room | 8 Keeping Room | 13 Master Sitting | 18 Bedroom    |                  |
| 4 Powder Room | 9 Laundry Room | 14 Master Bath    | 19 Bathroom   |                  |
| 5 Library     | 10 Wet Bar     | 15 Covered Porch  | 20 Upper Hall |                  |























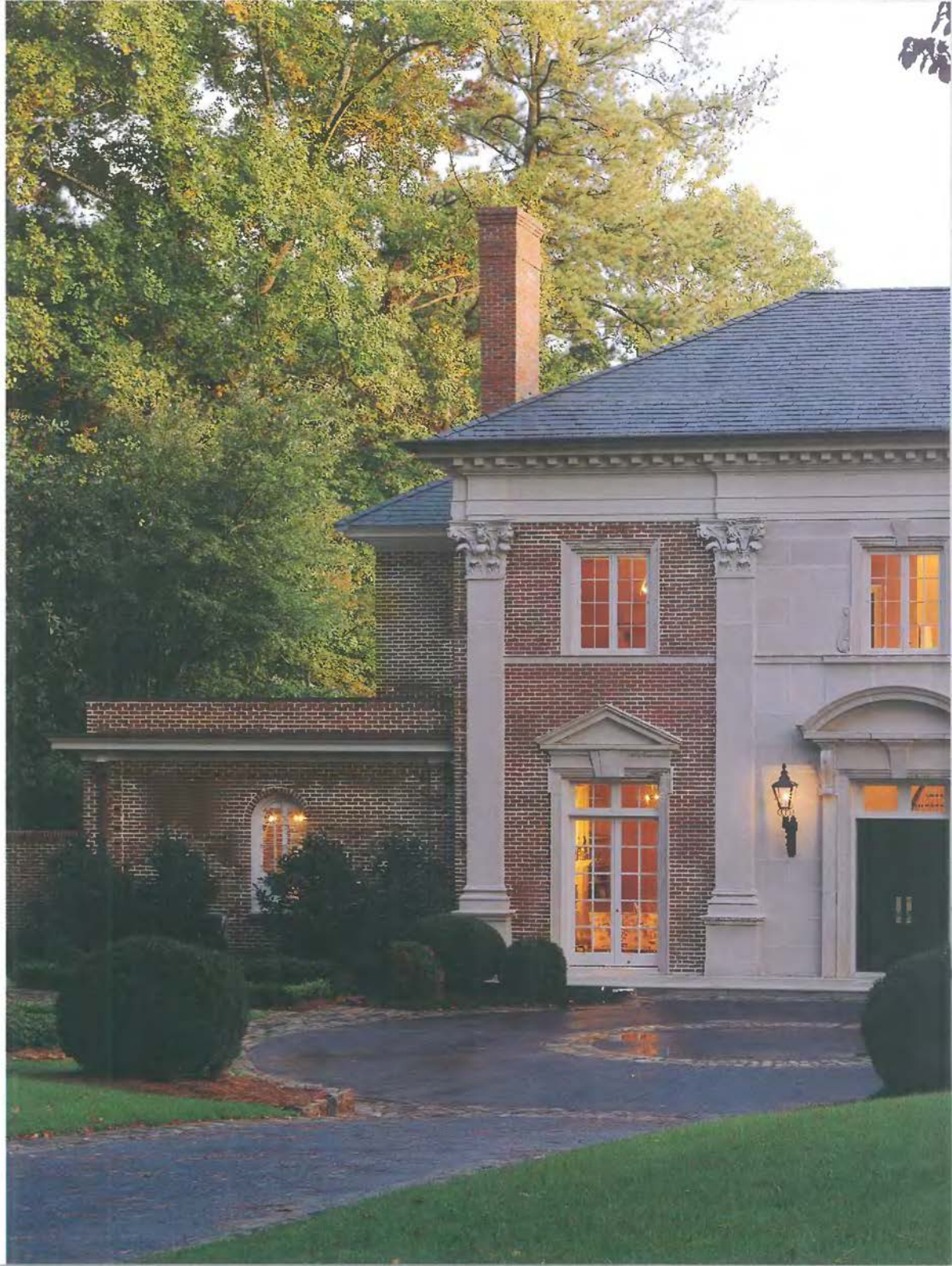







# THE DEMPSEY HOUSE

Greenville, South Carolina, 1992–1993

*Lynn Yeargin, Builder*  
*Interiors by Louise Quinn*

Mr Dempsey is a man who has achieved the American dream like few others. Born to a modest family in Landrum, South Carolina, he rose through corporate America to become president or chairman of three Fortune 500 companies—Borg-Warner, Chemical Waste Management, and PPG. As a tribute to his personal and business achievements, he received the *Horatio Algers Award for Distinguished Americans* in 1995. Mr Dempsey also serves as a member of Clemson University's President's Advisory Board and the Dean's Advisory Board for the School of Engineering.

In his retirement, Dempsey returned to his roots and built his home in a country club community in Greenville, South Carolina, not far from his hometown of Landrum. Because of his corporate and community work, Mr Dempsey and his wife of 48 years, Harriet, needed a home that could function for large social gatherings yet still meet the needs of their extended family. The resulting house, with its grand rotunda and elegant interiors, is balanced by its informal family spaces designed for use by the family's many grandchildren.

"For us, family comes first. This home has been a wonderful gathering place for all of us, especially when our family joins us here for the holidays," says Mrs Dempsey. "Whether it's a corporate event, a spend-the-night for the grandchildren, or a small group of friends for a game of bridge, the house has provided the perfect setting."













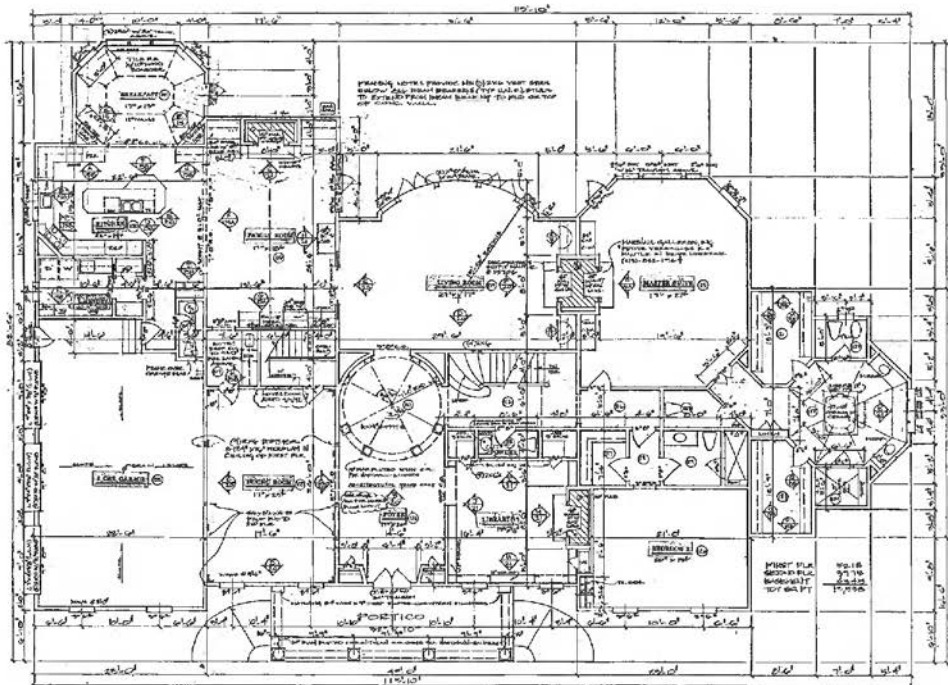
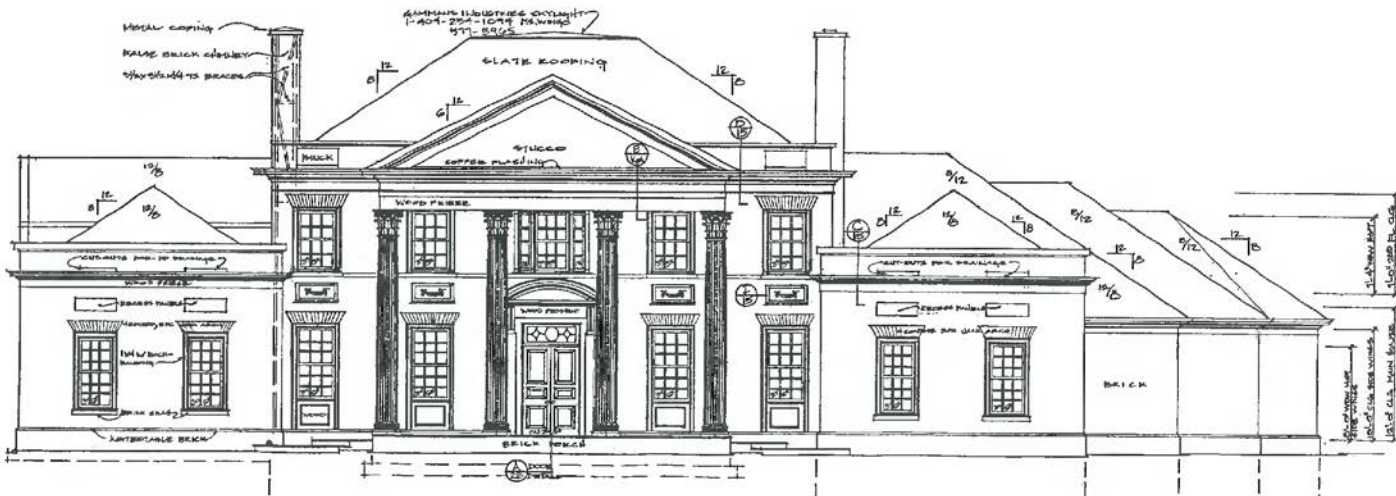

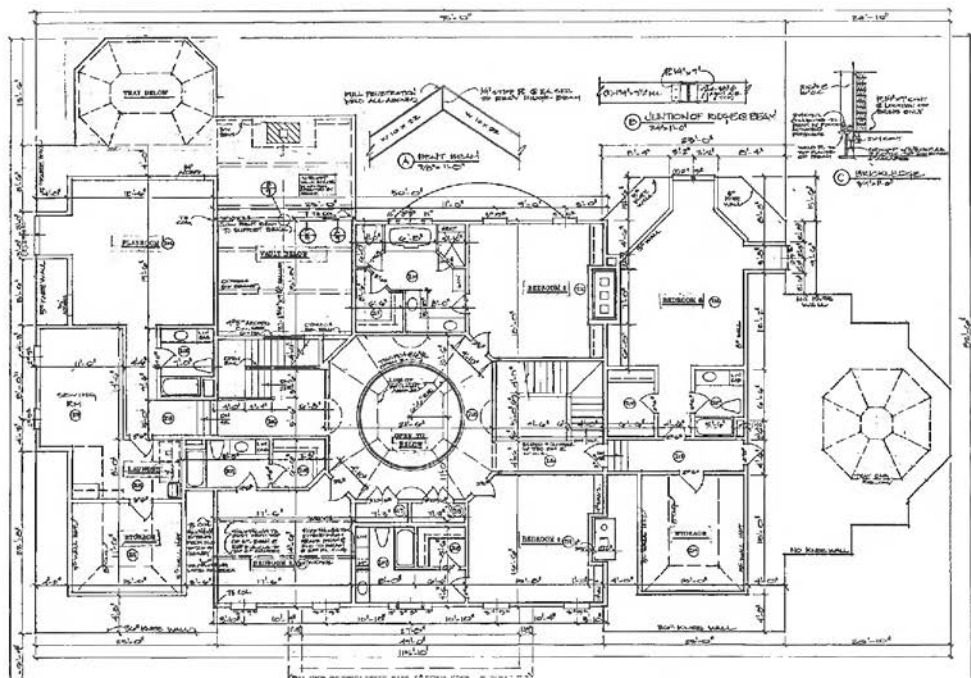
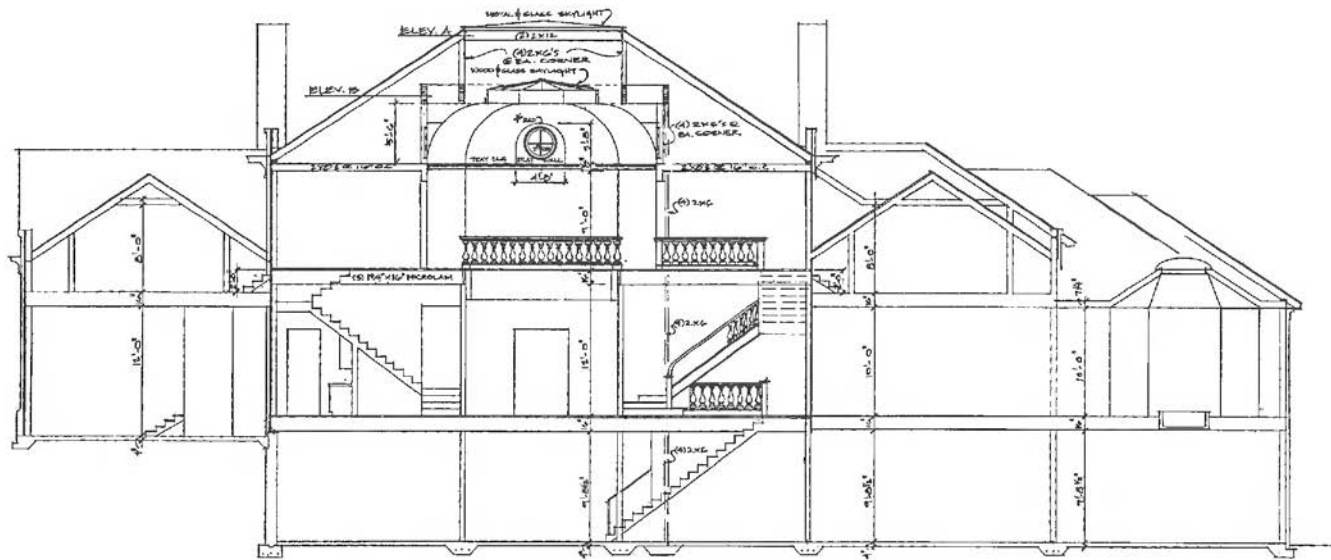



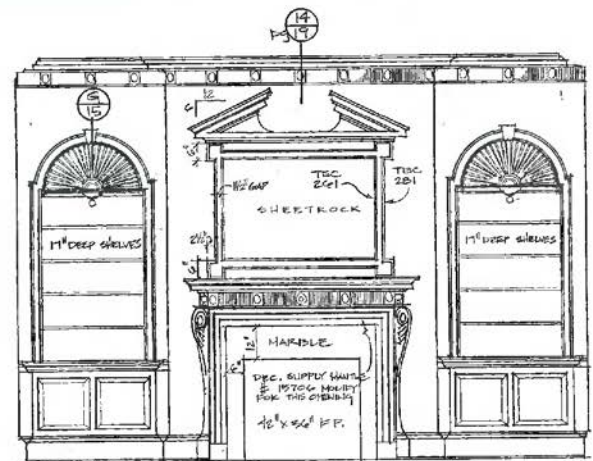
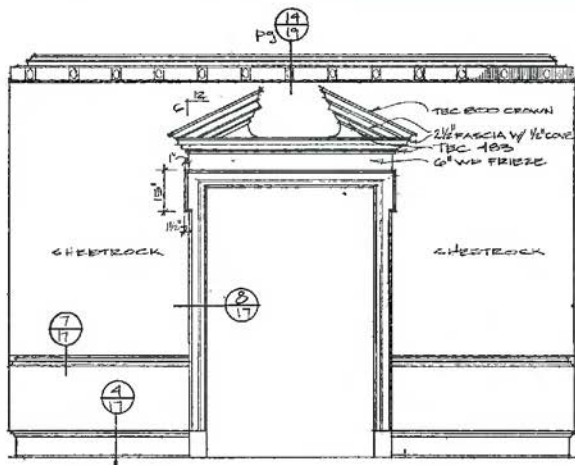











# THE BALDWIN HOUSE

Atlanta, Georgia, 1995–1996

*Mike Goodsell, Builder*  
*Interiors by Ann Baldwin*

Built of aged fieldstone with a Vermont slate roof, the Baldwin house is nestled in the woods on a tree-lined street that looks as if it could be in rural New England. Behind the house is a babbling stream that cascades over mountain rock into a small pond. One can hear the sound of the small waterfall when sitting on the rear screened porch. The house is a welcome retreat from Mr Baldwin's high-powered professional life.

"One might have expected the project to be a challenging one given that Mr Baldwin builds large commercial projects all over the world. He has very high standards for construction. Fortunately, we had great rapport throughout the project and I continue to value our friendship to this day," says Mr Baker. "The finished house is a delight to look at and I consider it one of my best works."

"This house is an oasis for us from our busy lives," says Mr Baldwin. "When I come home I feel totally removed from the stresses of living in a major city. It has been a real pleasure living in this house."







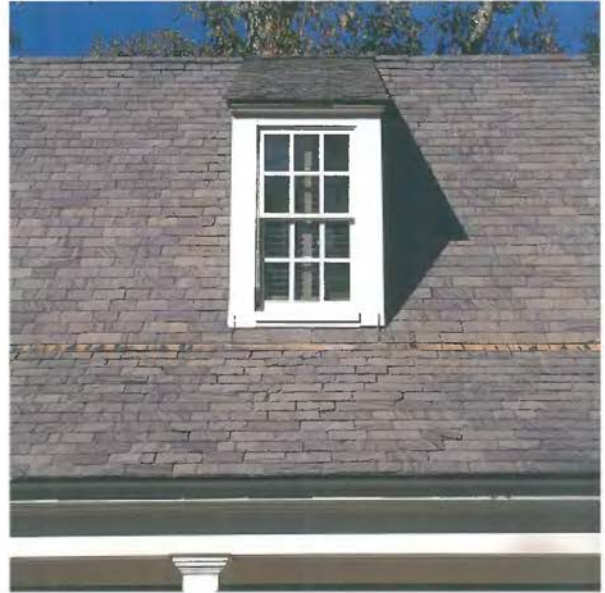

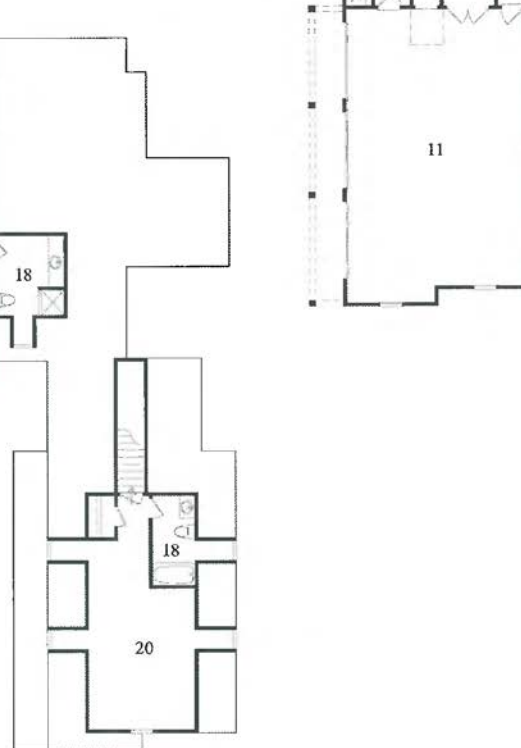
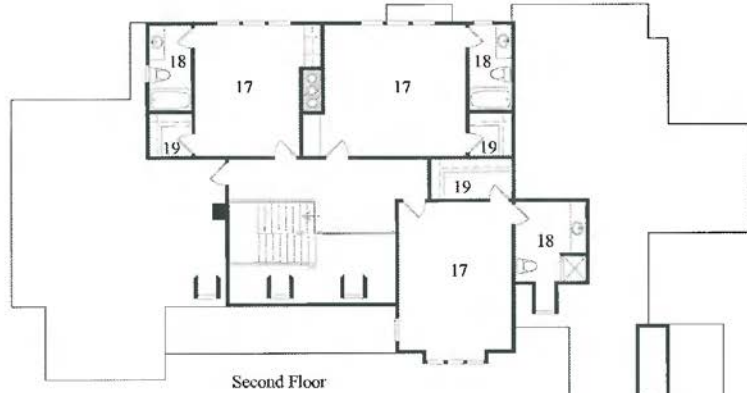
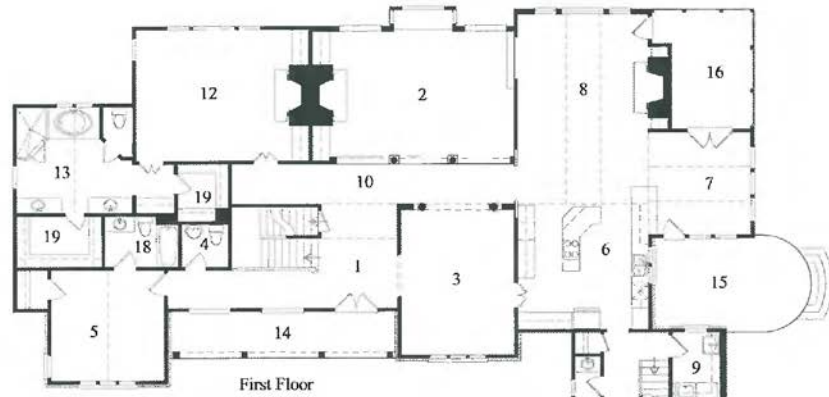

- 1 Foyer
- 2 Living Room
- 3 Dining Room
- 4 Powder Room
- 5 Guest Room

- 6 Kitchen
- 7 Breakfast
- 8 Keeping Room
- 9 Laundry Room
- 10 Gallery

- 11 Garage
- 12 Master Suite
- 13 Master Bath
- 14 Front Porch
- 15 Patio

- 16 Screened Porch
- 17 Bedroom
- 18 Bathroom
- 19 Closet
- 20 Bonus Room



























# THE SLONE HOUSE

## “ARCADIA”

Atlanta, Georgia, 1995–1997

*Craig Shelton, Builder*  
*Interiors by the Owner*

Located on one of the highest points in Atlanta, the Slone residence shares an important piece of local history. It was here in 1864, during the American Civil War, that Federal troops established an observation post with a strategic view of Atlanta. “There were still remnants of the fortifications from the war, but we failed to find any artefacts during excavation—to everyone’s disappointment,” comments Mr Baker.

The house was sited on top of the hill to take advantage of the downtown skyline view at night, and the long wooded approach up the hill. The dramatic double-ramp staircase showcases the antique limestone entry and its massive oak door. Once inside that door, guests can appreciate the many architectural antiques incorporated by the owner—lighting fixtures, flooring tiles, and interior doors—all planned to add to the home’s relaxed European feel.

Behind the house are a series of terraces and gardens in the Italian manner. Culminating the view, on axis with the house, is a baroque-style greenhouse, its graceful shape providing a visual anchor for the pool and multi-level terraces. “The greenhouse is one of our favorite things about the property,” says Mrs Slone. “Its stone eagle finial keeps watch over my prized orchids. This property is a horticulturist’s dream. I love the way the colors and textures change with the seasons.”







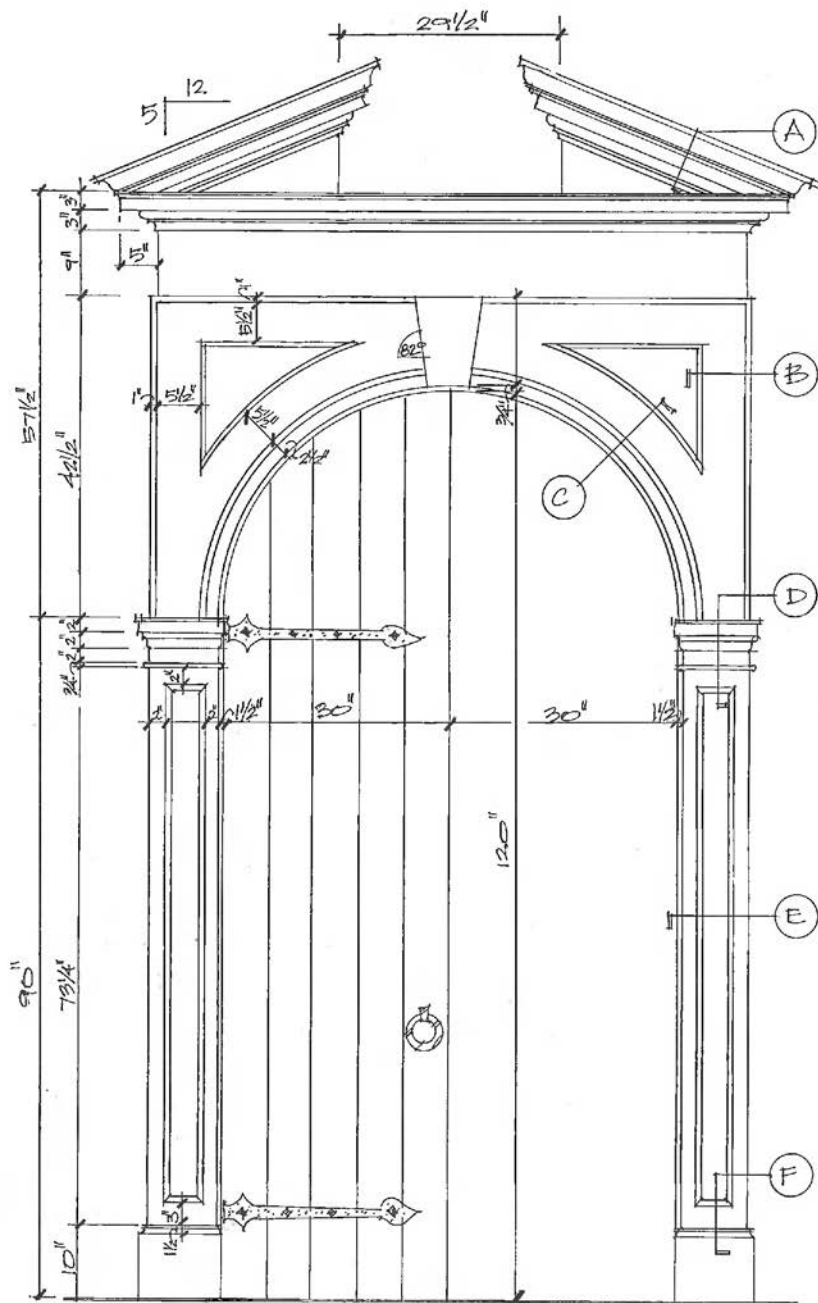

FRONT ENTRY INT. TRIM  
 $3/4'' = 1'-0''$







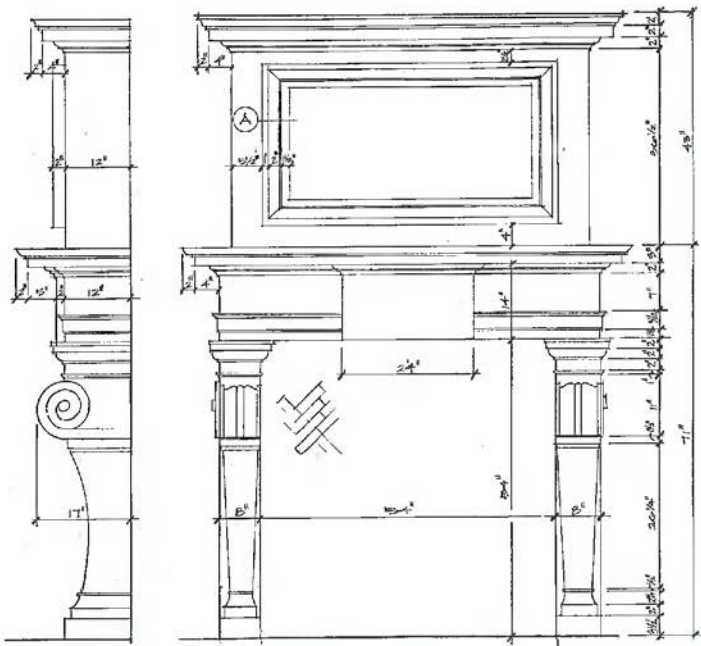







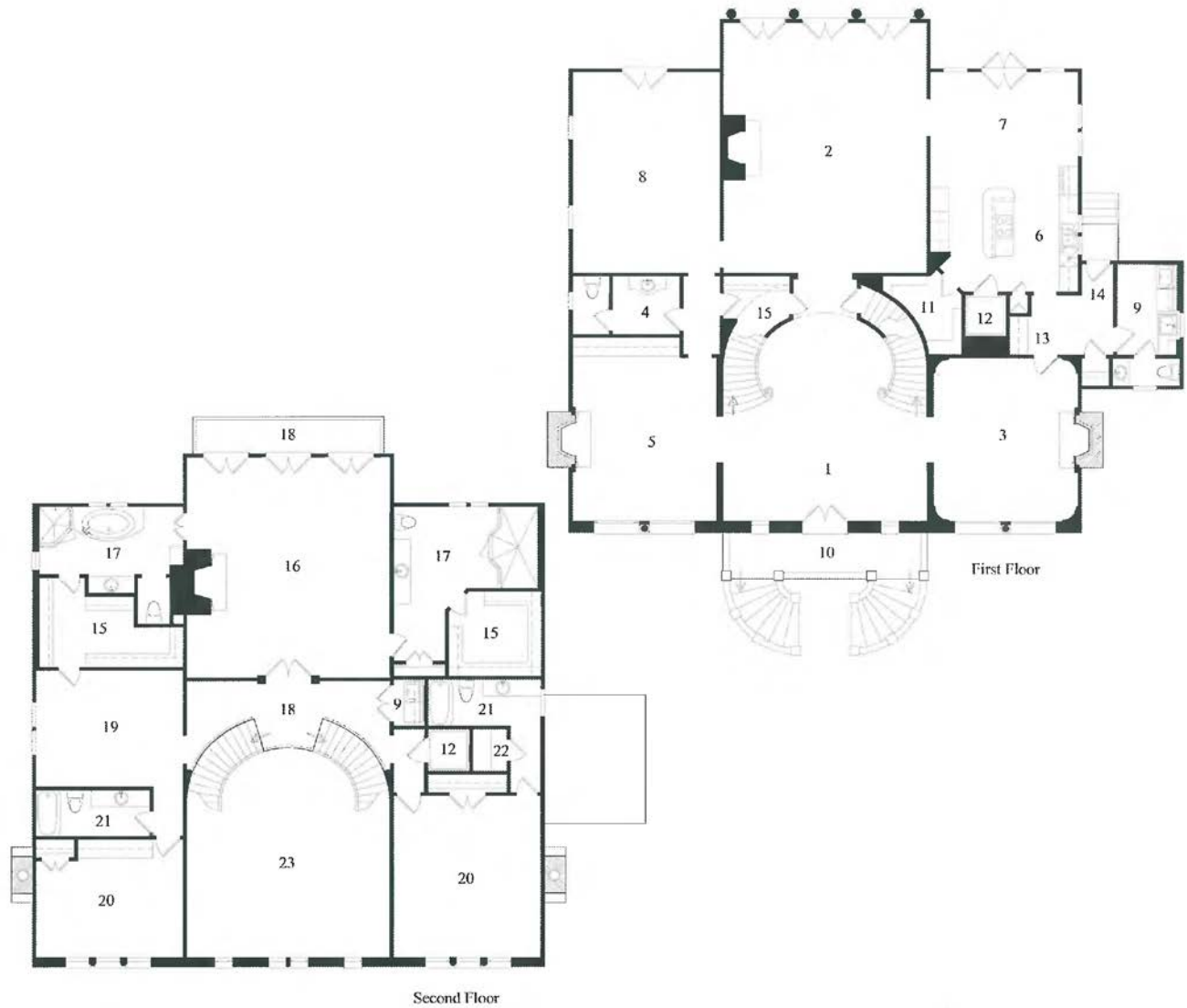

- |                 |                  |                   |                 |                  |
|-----------------|------------------|-------------------|-----------------|------------------|
| 1 Foyer         | 6 Kitchen        | 11 Pantry         | 16 Master Suite | 21 Bathroom      |
| 2 Living Room   | 7 Breakfast      | 12 Elevator       | 17 Master Bath  | 22 Linen         |
| 3 Dining Room   | 8 Family Room    | 13 Butlers Pantry | 18 Balcony      | 23 Open to Below |
| 4 Powder Room   | 9 Laundry Room   | 14 Service Entry  | 19 Exercise     |                  |
| 5 Paneled Study | 10 Front Terrace | 15 Closet         | 20 Bedroom      |                  |









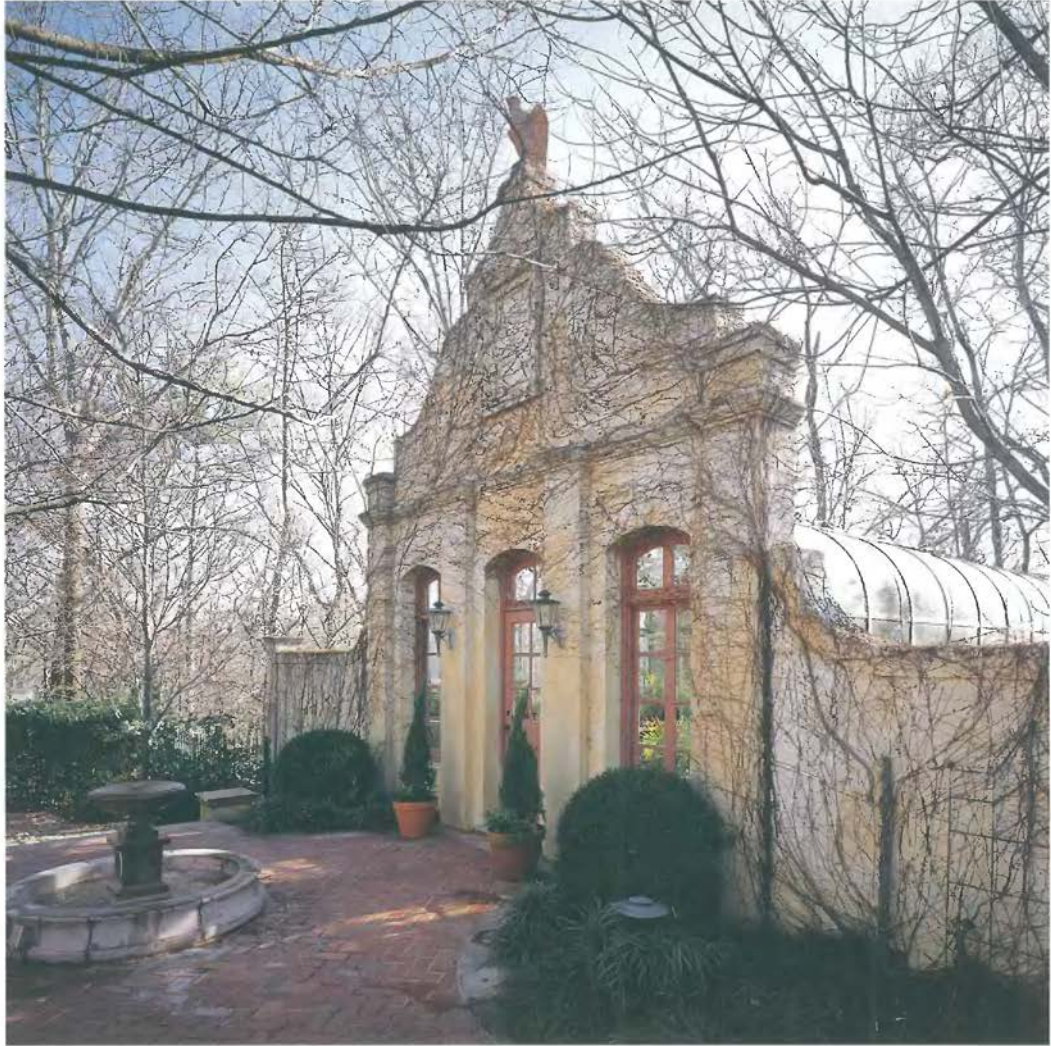



# THE NOONAN HOUSE

Atlanta, Georgia, 1996–1998

*Mark Palmer, Builder*

*Interiors by Suzanne Kasler Interiors*

"With only a glimpse of the Corinthian capitals, classic lines, and the lush grounds, we instantly fell in love with our house—it was like finding an English estate in the middle of the city," says Mr Noonan. The home's use of hand-carved Indiana limestone, old Carolina wood-molded brick, and Vermont slate roof are the perfect compliment to the architectural design of this modern day English country estate.

The limestone Corinthian capitals, with their southern flowers, were carved by English artist Nicolas Fairplay, while the monumental segmental front entry and other stonework was produced by Atlanta's Sherwood Cut Stone. The home's grand interiors are the result of Mr Baker's tasteful designs, which are based on interiors of the period.

On life since moving in, Mrs Noonan relates, "In addition to the main floor, maybe the most used area of the house is the spacious lower level. This is where our media room, wine cellar and my husband's office are located. Our children can have their friends over, watch movies, and have fresh popped popcorn from the old-fashioned popcorn machine in the adjoining kitchen. Meanwhile I can be working nearby or my husband and I can entertain the parents of our children's friends in our wine tasting room. This home is the perfect balance of form and function. We are really proud of it and so comfortable in the casually elegant setting."













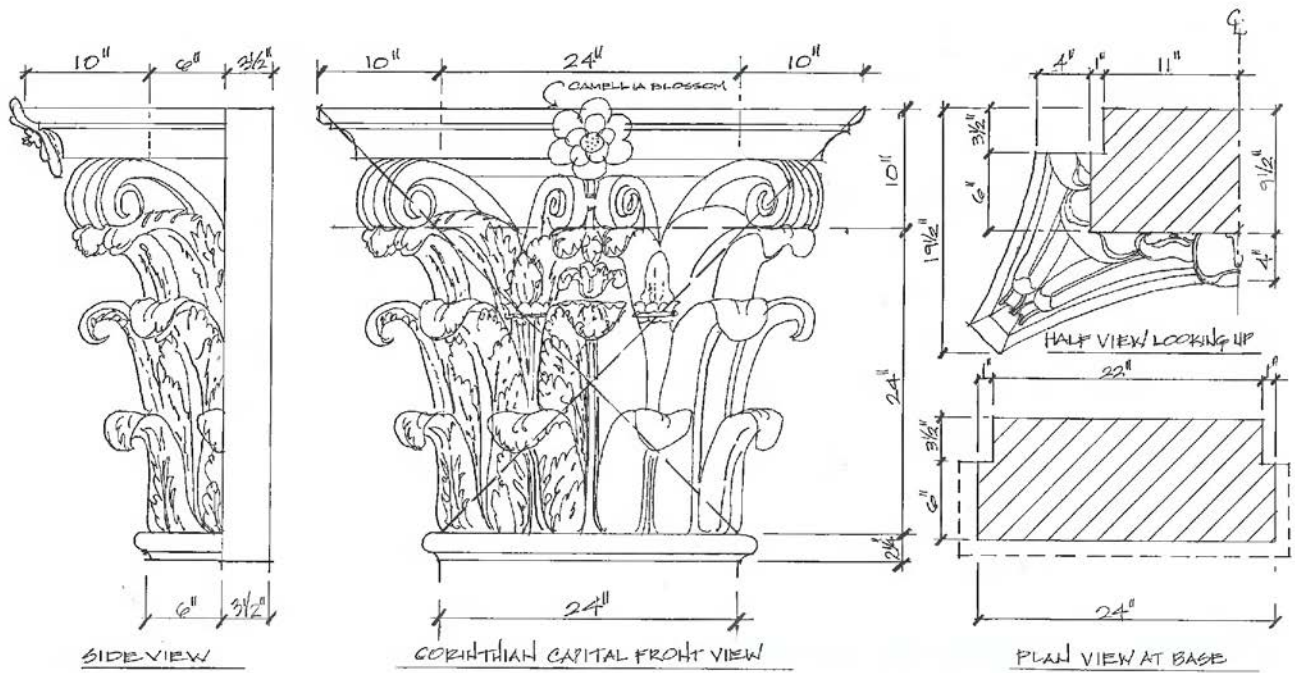

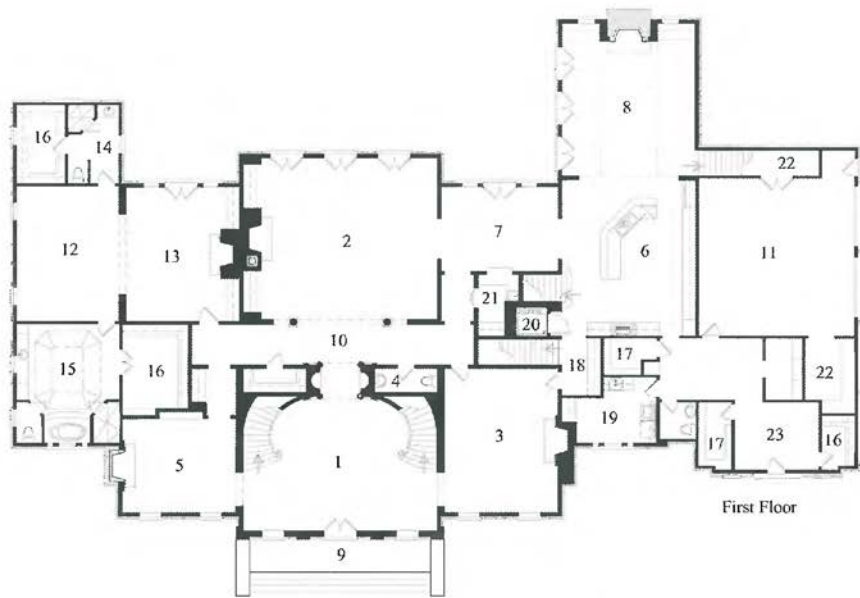

- |               |                |                   |                    |                     |                  |
|---------------|----------------|-------------------|--------------------|---------------------|------------------|
| 1 Foyer       | 6 Kitchen      | 11 Garage         | 16 Closet          | 21 Wet Bar          | 26 Bedroom       |
| 2 Living Room | 7 Breakfast    | 12 Master Bedroom | 17 Pantry          | 22 Storage          | 27 Bathroom      |
| 3 Dining Room | 8 Keeping Room | 13 Master Sitting | 18 Butler's Pantry | 23 Service Entrance | 28 Open to Below |
| 4 Powder Room | 9 Terrace      | 14 His Bath       | 19 Laundry Room    | 24 Mechanical       | 29 Sitting Room  |
| 5 Library     | 10 Gallery     | 15 Her Bath       | 20 Elevator        | 25 Study            |                  |









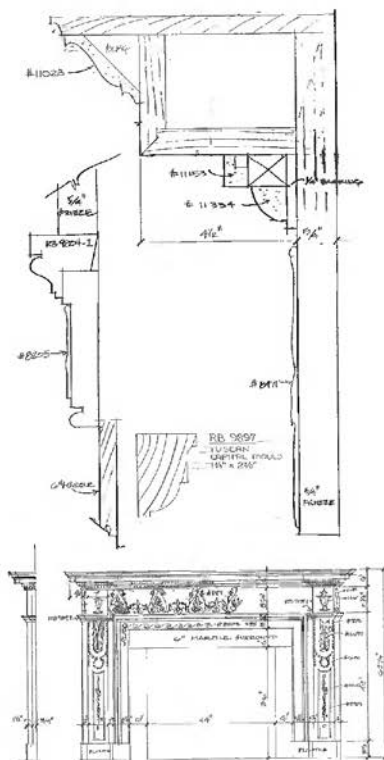























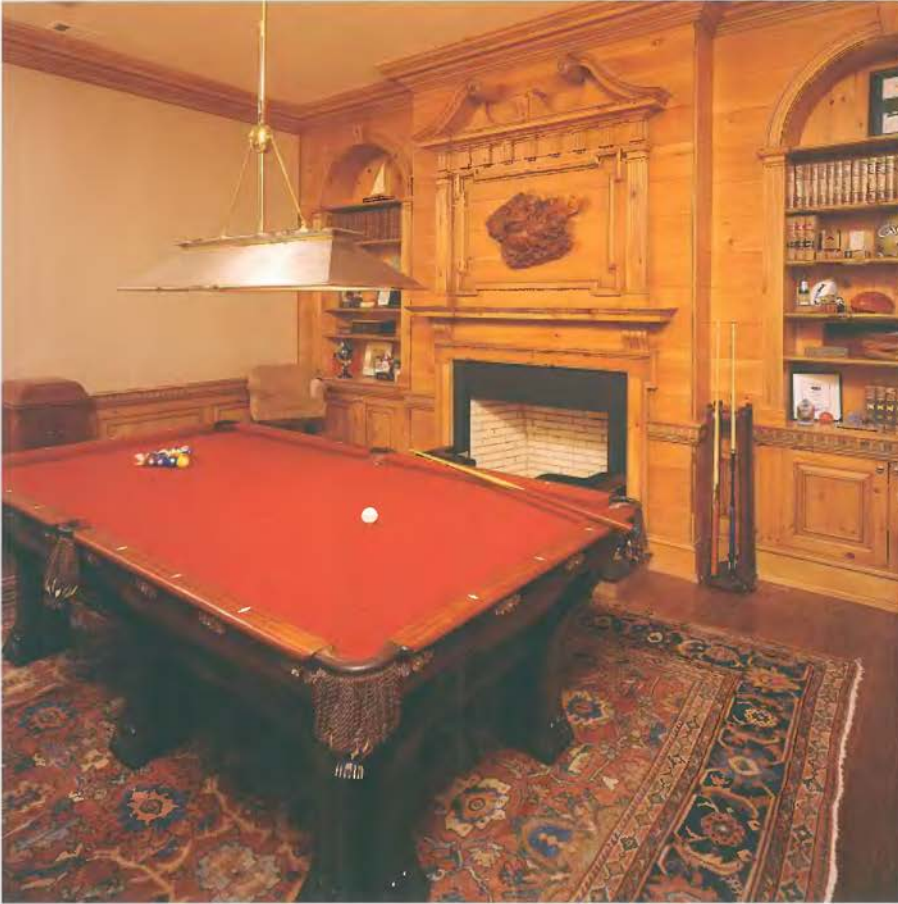





# THE ANTHONY HOUSE

Atlanta, Georgia, 1996–1998

*Robert Maret, Builder*

*Interiors by Ruth Dobbs Anthony*

"The challenge for this house was to design the home with all of Mrs Anthony's antiques and art in mind," says Mr Baker. "She has some beautiful family portraits and special pieces of furniture for which we wanted to be sure to provide a place." Over the years, Mrs Anthony, an accomplished designer in her own right, had acquired a large collection of objects d'art, which challenged Mr Baker to create interesting display opportunities. "One of my favorite spaces is the octagonal hall with its display niches for my porcelain," says Mrs Anthony.

To compliment the antiques, the interiors were designed to provide a perfect setting for the furnishings. "The company that supplied our moldings provided us with the same cornices and trim that were available a century ago," says Mr Baker. "In some areas of the house, I combined off-the-shelf items with custom fabrication to create the desired architectural elements. The living room door pediment is one example."

"My favorite room in the house is the mirrored trellis room," says Mr Baker. "It is the first time I have created an effect like this." The room, with its wood lattice and fluted Ionic pilasters mounted over mirrors, provides a dazzling effect during the day and a dramatic soft glow at night. Mrs Anthony comments, "I love the bright cheerfulness of the house. It gives a happy feeling to the start of each day."











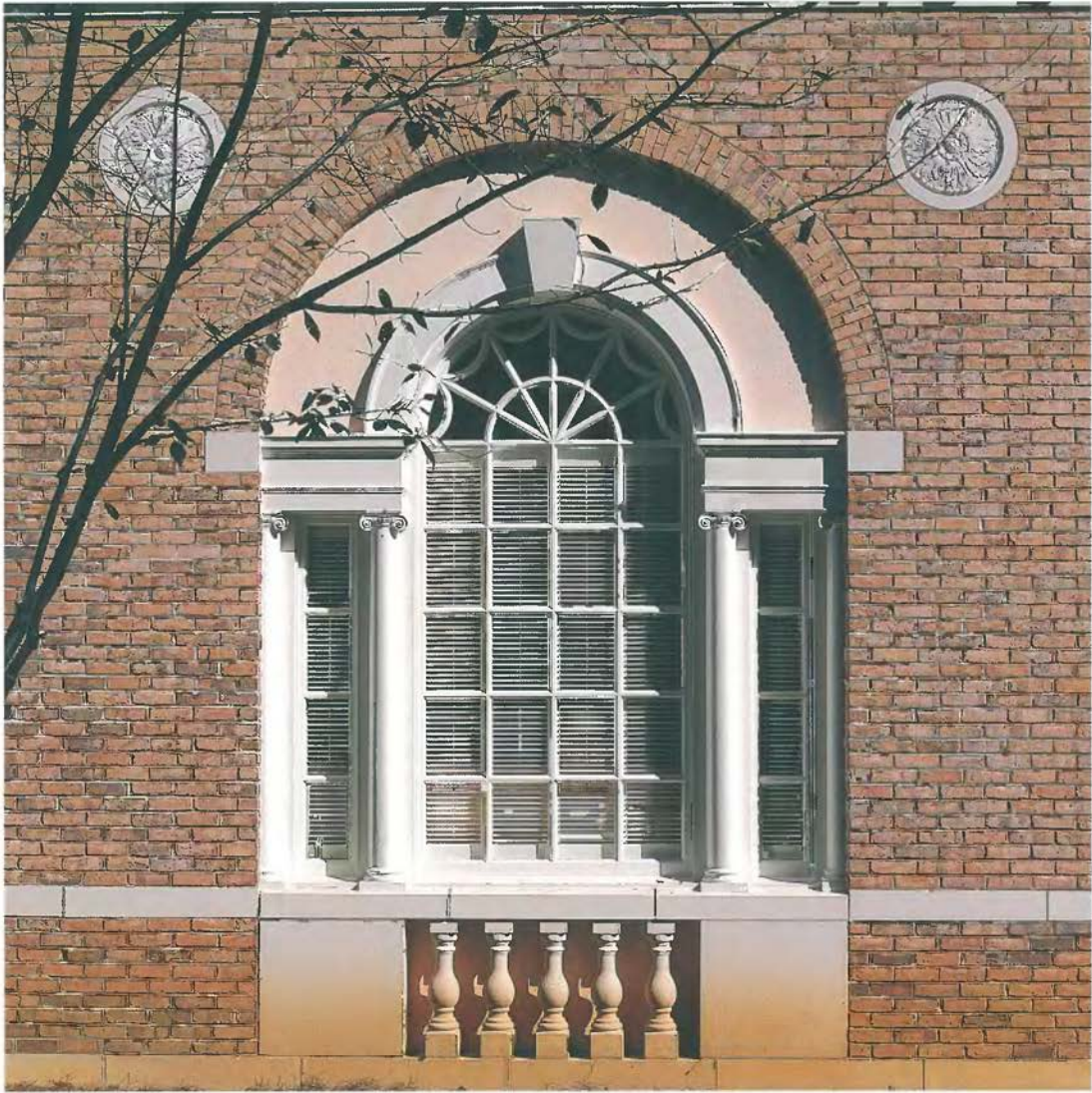



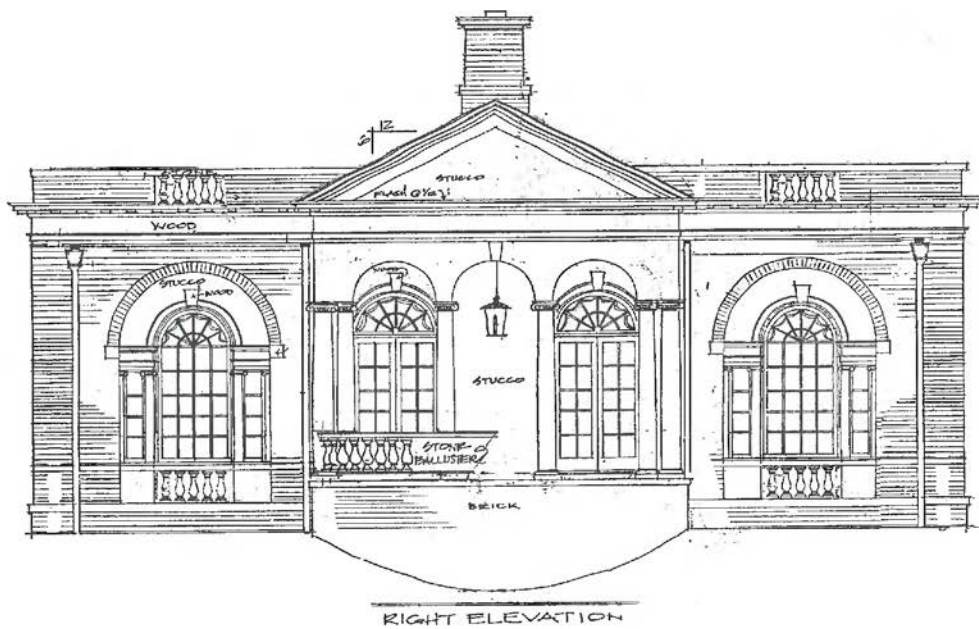

RIGHT ELEVATION

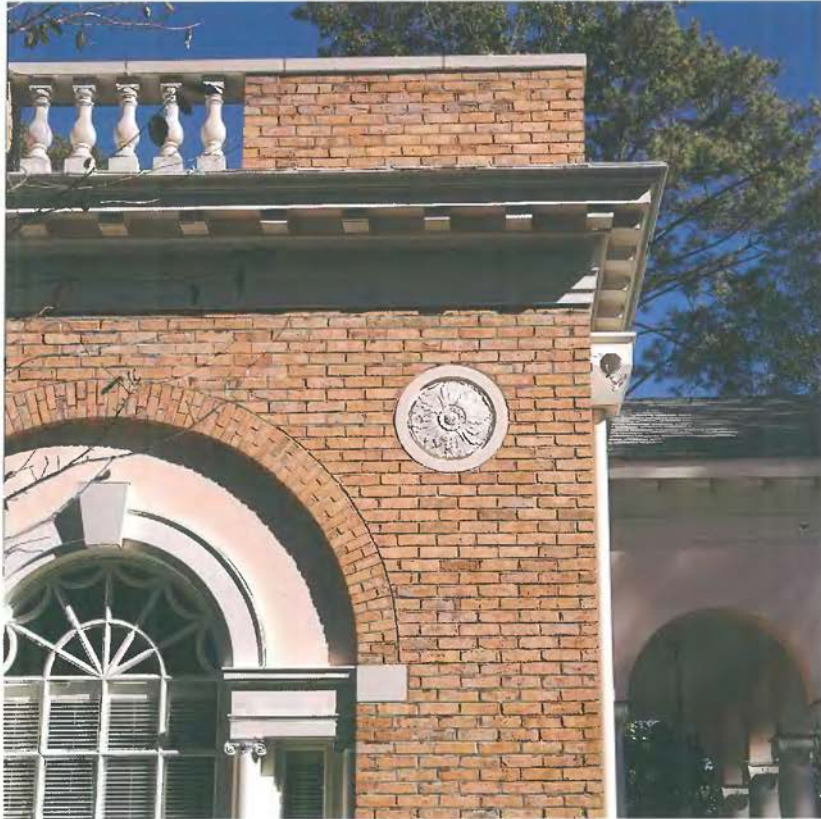



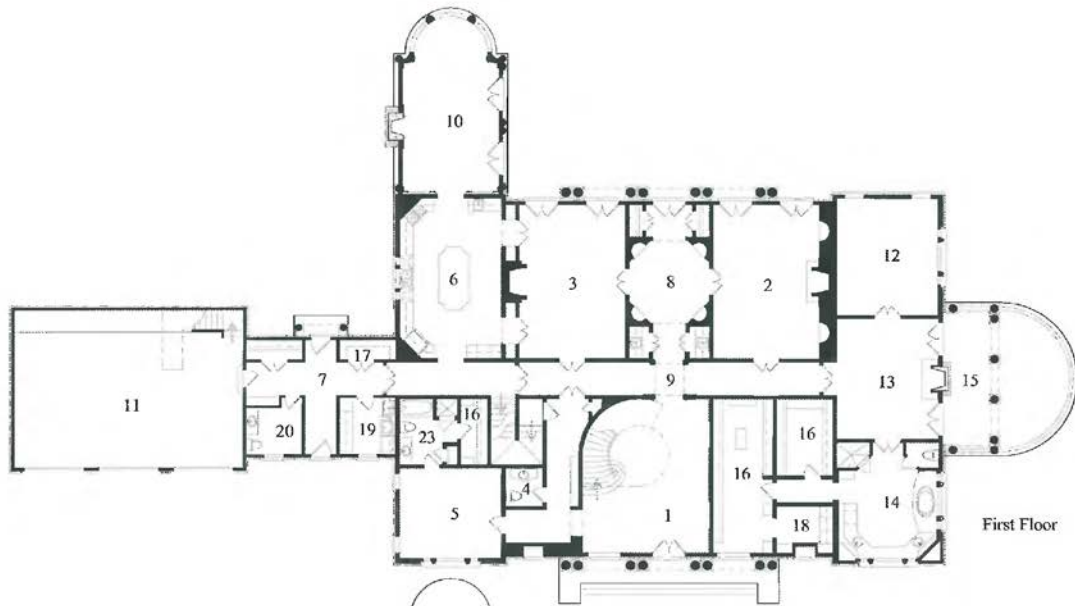

First Floor

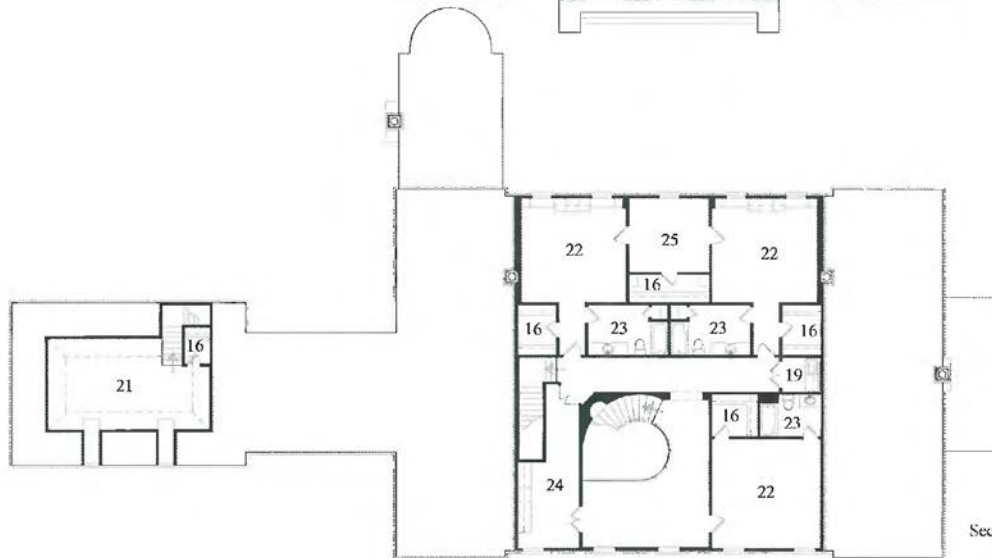

Second Floor

- |               |                 |                   |                 |                  |
|---------------|-----------------|-------------------|-----------------|------------------|
| 1 Foyer       | 6 Kitchen       | 11 Garage         | 16 Closet       | 21 Bonus Room    |
| 2 Living Room | 7 Service Entry | 12 Master Suite   | 17 Pantry       | 22 Bedroom       |
| 3 Dining Room | 8 Vestibule     | 13 Master Sitting | 18 Office       | 23 Bathroom      |
| 4 Powder Room | 9 Gallery       | 14 Master Bath    | 19 Laundry Room | 24 Computer Room |
| 5 Guest Suite | 10 Trellis Room | 15 Covered Porch  | 20 Service Bath | 25 Sitting       |





































# THE GREGORY HOUSE

Atlanta, Georgia, 1996–1999

*McGarrity-Garcia Residential, Builder*  
*Interiors by Dee Dee Owens*

Mr Gregory and his wife retired to Atlanta after his serving as president of a New York-based Fortune 500 company. Because of their love of Atlanta, they returned to build a home in a country French style. "My wife has always loved the look of country French, so I wanted her to have just what she wanted," says Mr Gregory. "We worked with Bill to achieve the casually elegant feel that fits our lifestyle best."

"The house has an unusual type of stone. I understand that this was the last amount available. I am pleased that we were able to get it for this house," says Mr Baker. "The texture of the wood shake roof and the rough-sawn wood shutters complement the stone and provide the textured look that the owners wanted."

The house looks out onto a wooded preserve that provides wonderful privacy for the rear pool and gazebo. With its flagstone and shaded arbor, the rear terrace is a welcome retreat on a warm summer day.











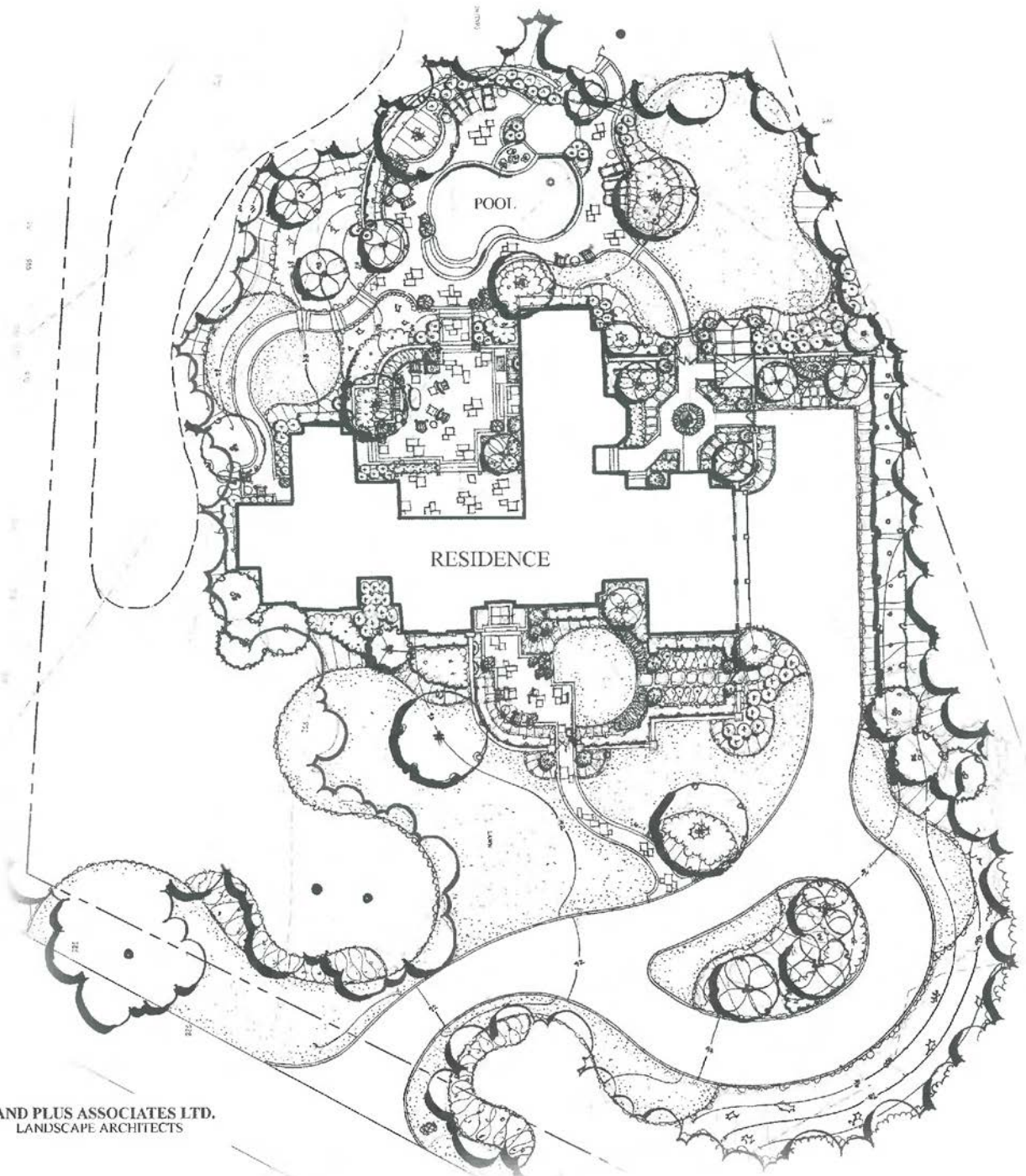

LAND PLUS ASSOCIATES LTD.  
LANDSCAPE ARCHITECTS



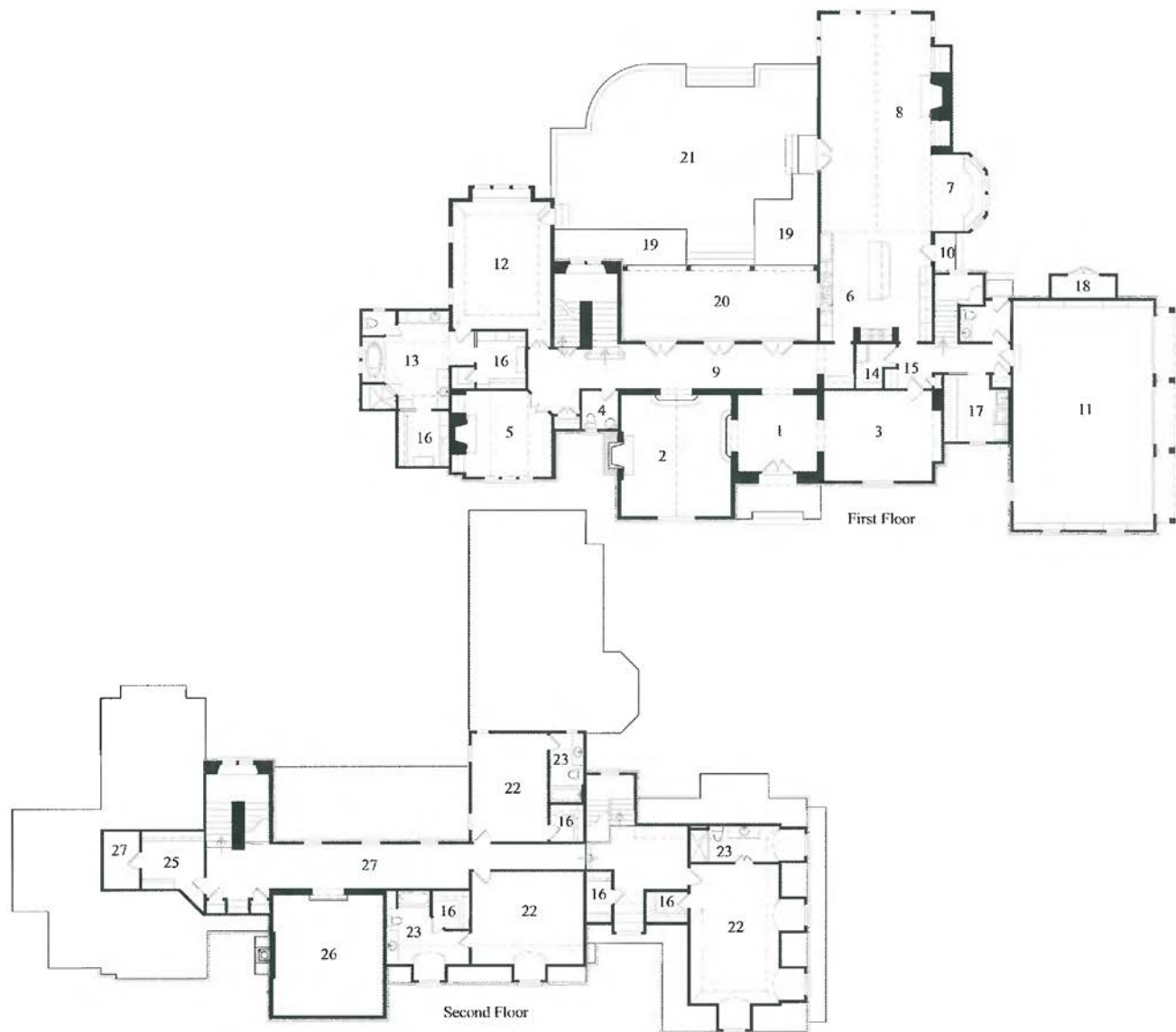

- |               |                  |                   |                  |                  |                  |
|---------------|------------------|-------------------|------------------|------------------|------------------|
| 1 Foyer       | 6 Kitchen        | 11 Garage         | 16 Closet        | 21 Stone Terrace | 26 Open to Below |
| 2 Living Room | 7 Breakfast      | 12 Master Suite   | 17 Laundry       | 22 Bedroom       | 27 Upper Gallery |
| 3 Dining Room | 8 Keeping Room   | 13 Master Bath    | 18 Storage       | 23 Bathroom      |                  |
| 4 Powder Room | 9 Gallery        | 14 Pantry         | 19 Planter       | 24 Linen         |                  |
| 5 Study       | 10 Service Entry | 15 Butlers Pantry | 20 Covered Porch | 25 Cedar Closet  |                  |



























# THE MILLS HOUSE

Atlanta, Georgia, 1997–1999

*Bob Goodsell, Builder*

*Interiors by Jane Williamson*

This is a house with a heritage. Mrs Mills' childhood home was an exquisite Colonial American-style home designed by James Means, an Atlanta architect well known for his residences in this vernacular. Having grown up in a landmark home decorated with period furniture, Mrs Mills is a connoisseur of the style, and informed on all aspects of the design. "It's a special treat for me when I encounter a client who is so informed on a specific style. Her thoughts on the design of the home came so easily because they were second nature for her," says Baker.

Among the special materials used on the house are its wood shake roof, hinged paneled shutters, weathered gray wood shake walls and an aged granite foundation. The house is set on a hill and tastefully landscaped with boxwoods. The interior walls were thickened at the windows to create pockets in the wall for the interior shutters just as Means did on his houses a generation earlier. The fireplace mantles are antique and help the interiors achieve the period look that so nicely complements the home's lovely furnishings.

"Our goal," says Mrs Mills, "was to create a house for our time that was true to the standards inspired by Jimmy Means. I think this house does justice to that end."















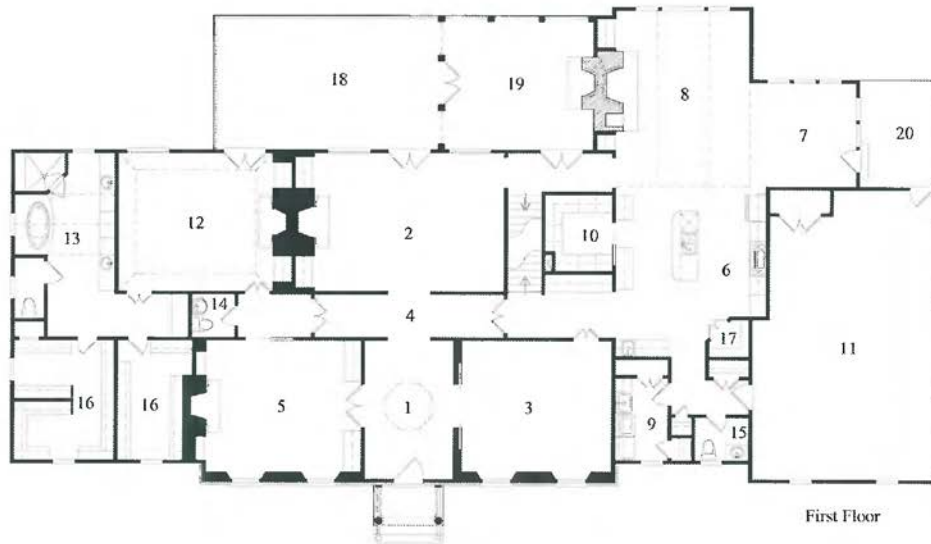

First Floor



Second Floor

- |               |                |                 |                   |               |                 |
|---------------|----------------|-----------------|-------------------|---------------|-----------------|
| 1 Foyer       | 6 Kitchen      | 11 Garage       | 16 Clost          | 21 Storage    | 26 Play Room    |
| 2 Living Room | 7 Breakfast    | 12 Master Suite | 17 Pantry         | 22 Bedroom    | 27 Cedar Closet |
| 3 Dining Room | 8 Keeping Room | 13 Master Bath  | 18 Terrace        | 23 Bathroom   |                 |
| 4 Gallery     | 9 Laundry Room | 14 Powder Room  | 19 Screened Porch | 24 Linen      |                 |
| 5 Library     | 10 Office      | 15 Service Bath | 20 Patio          | 25 Study Area |                 |





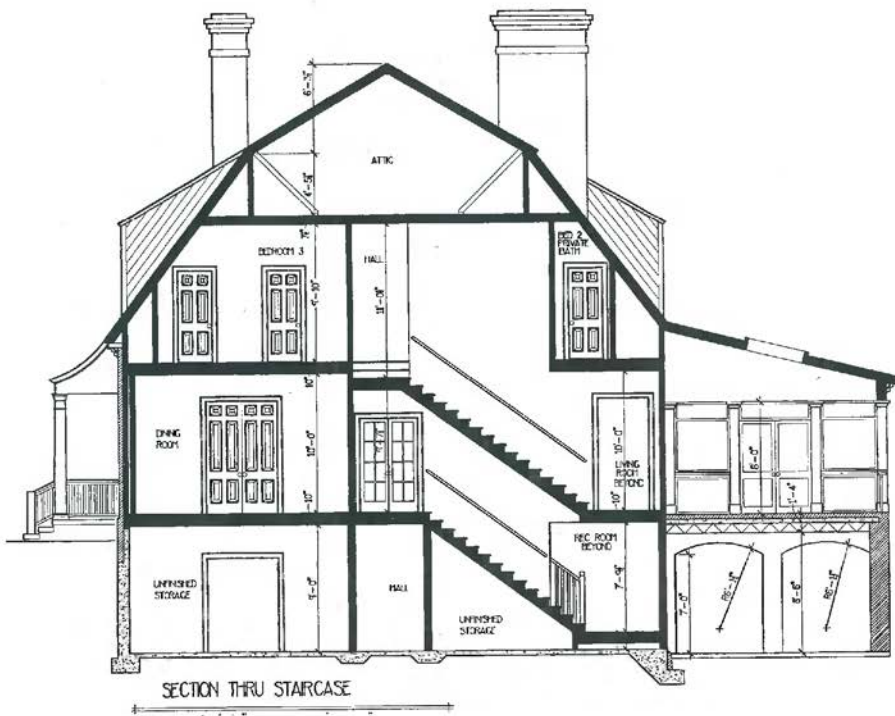
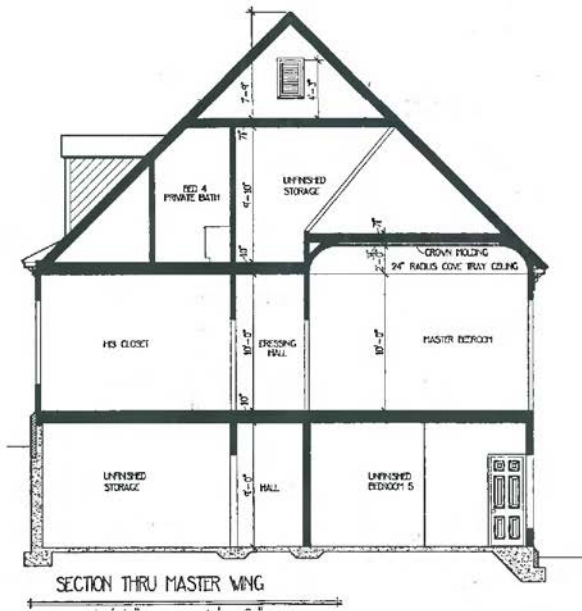













# THE JOHNSON HOMEPPLACE

Near Atlanta, Georgia, 1997–1999

*Built by the Owner*  
*John Campbell, Contractor*

Mr Johnson, a developer of large commercial real estate projects, has always taken a hands-on approach to designing, building and managing his award-winning projects. Over the years, he and his wife studied numerous examples of late 19th-century architecture on their many travels with the idea that one day they would create their own Queen Anne home.

When the Johnsons came to Bill Baker, they were well prepared with many photographs and architectural design books. “We studied the homes to identify the most important architectural elements for our design—the asymmetrical gable, the octagonal turrets, the wrap-around porches, the different wood shake patterns, the detailed brick work and the heavily bracketed cornice,” says Mr Baker. “The challenge was to produce an open floor plan for today’s lifestyle while remaining architecturally true to the form and scale of a house from a century earlier.”

The placement of the house in its park-like setting and the orientation of the windows was inspired by the work of 1850s architect, A. J. Downing. Downing wanted to relate his interiors to the outdoor environment through the use of large windows and inviting porches. Visitors to the Johnson’s house give testimony to the success of achieving the look and feel of a house from an earlier era.

The interior architecture makes use of many of the materials and special features characteristic of the period. “Of special note are the stained-glass dome in the foyer, the custom-made oak mantle in the living room that could pass for an architectural antique, window casings with egg-and-dart moldings, the hand-etched frosted glass panels at the front door and the elaborate coffered ceiling of pressed tin in the living room,” says Mr Baker. “The beautiful quarter-sawn oak paneling and floors provide a striking background for the period furnishings.” The interior millwork installation took five master cabinet makers sixty weeks to complete while the interior paint and faux finishes took eight painters and artists over fourteen months to complete.









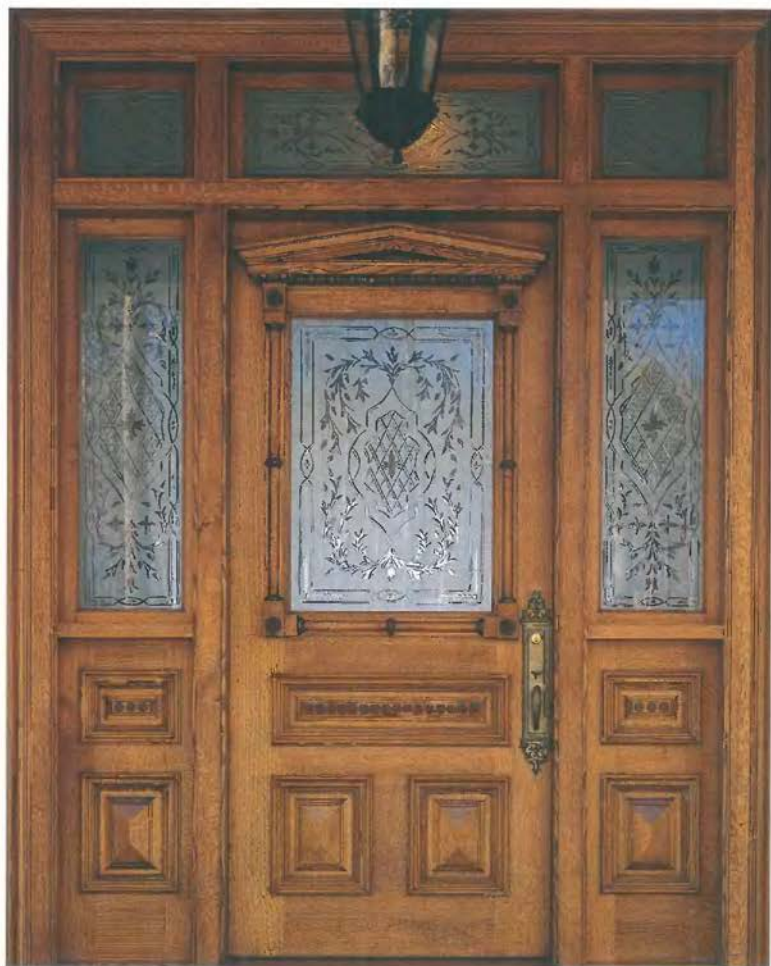













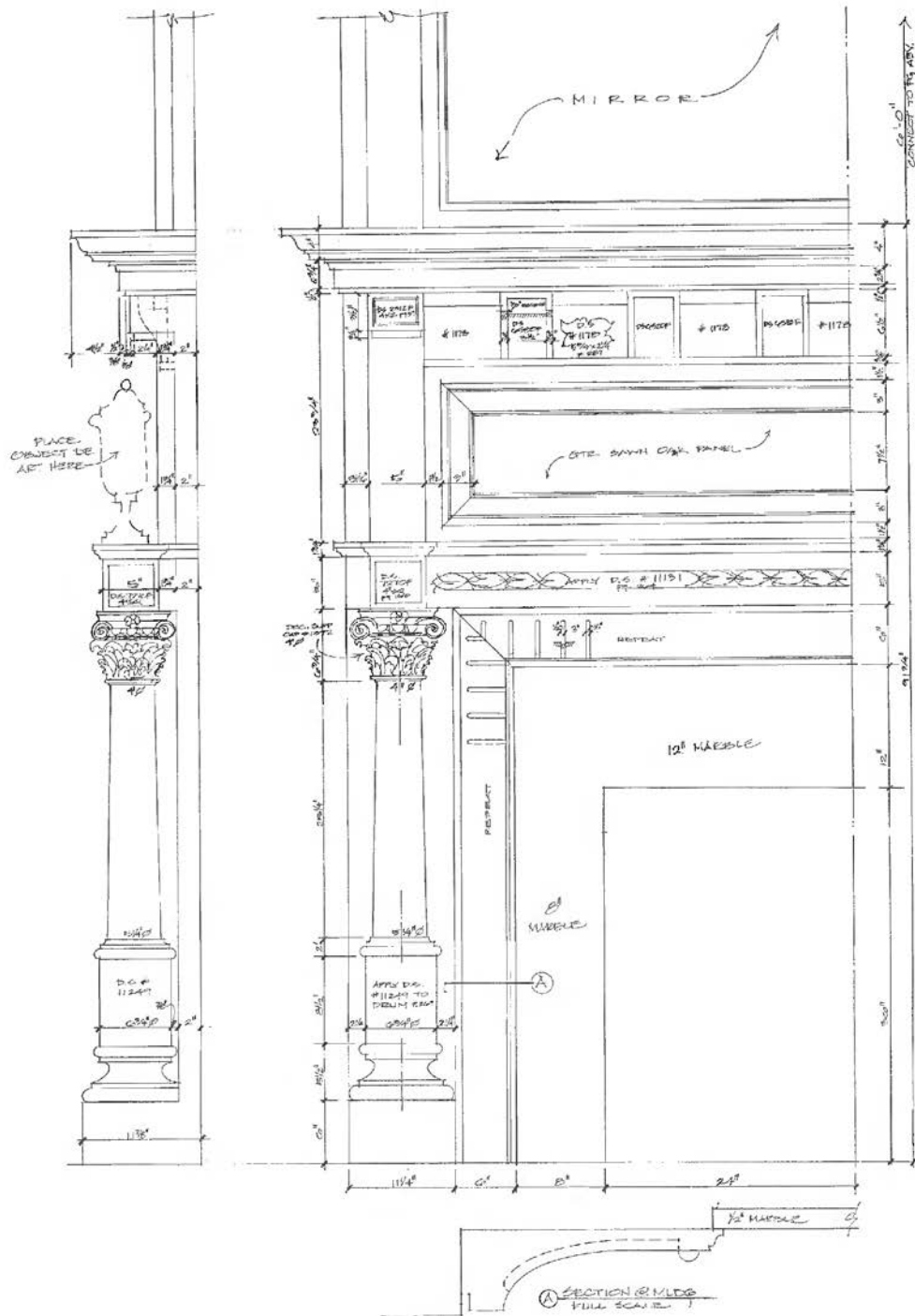

























# THE SMIDT HOUSE

Atlanta, Georgia, 1997–1998

*Jon Bernulsen, Builder*  
*Interiors by Judy Bentley*

Originally a 1950's brick ranch, the Smidt house represents one of Mr Baker's most incredible transformations of an existing house into a stylish country French house. The original house was characterized by a low-pitched roof and horizontal lines.

"People had noticed the original house primarily because of the incredible setting with its mature trees and sweeping lawn," recalls Mr Baker. "It was always one of my favorite properties in town, so I was excited to be the one chosen to enhance it."

In creating the new house, Mr Baker raised the roof, added French-style dormers, lengthened the front windows, veneered the brick in cream-colored stucco and added an architectural door surround at the entry.

The Smidts have a love for all things French and enjoyed enhancing the project with the architectural antiques they found in Paris. Of special note is the old limestone mantle in the living room that they found at the Paris flea market. "Half the fun of this project was filling the house with the things we love," says Jenny Smidt. "It has been an ongoing project which we have enjoyed very much. Bill Baker gave us a wonderful house with which to work."

*Before*

























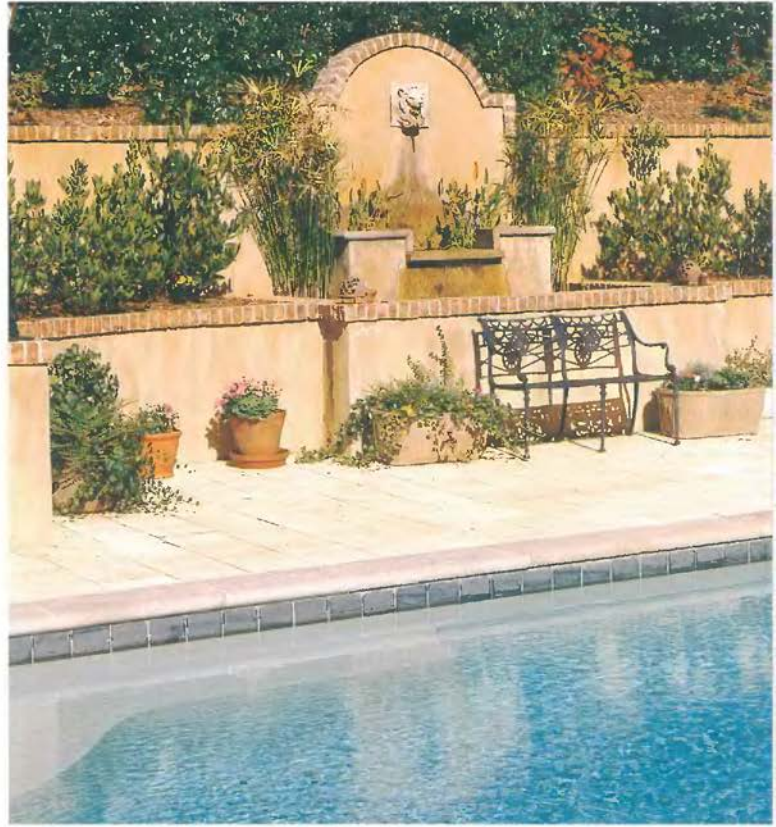



# THE SCHINDLER HOUSE

Atlanta, Georgia, 1997–1998

*Jerry Hicks, Builder*  
*Interiors by Alan Kepner*

The Schindlers moved to Atlanta from Boca Raton, Florida, in 1997. As a venture capitalist, Mr Schindler could locate his business to any city and chose Atlanta because of its attractive business climate.

The Schindlers purchased a lot in northwest Atlanta that, at first glance, looked topographically challenging. With one ravine in the front and another in the rear, it looked as though the house would have little usable yard. But, as Mr Schindler recounts, "I coordinated the grading of the lot with my immediate neighbor to the advantage of both parties." The totally transformed property provides a lovely park-like setting for the French-style home.

With its dramatic domed foyer, 14-foot ceilings, and expansive floor plan, the house is ideal for entertaining. "We love opening our home to family and friends or using it to host the various organizations that we support."

Mrs Schindler's love of gardening is readily apparent throughout the property. In the spring, blossoming azaleas and dogwood trees surround the house. "I created a large parterre garden, bordered in boxwood, near the rear terrace that is planted with beautiful white roses for cool summer color," says Mrs Schindler. "Outside the kitchen windows are flower boxes with a variety of old-fashioned flowers that cascade over the sides in a profusion of color. I wanted to have color and variety all around the house."









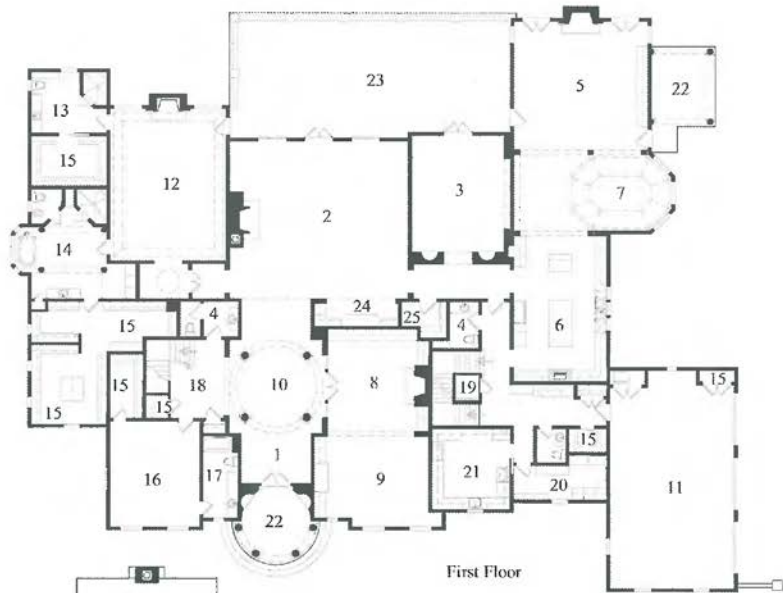

First Floor

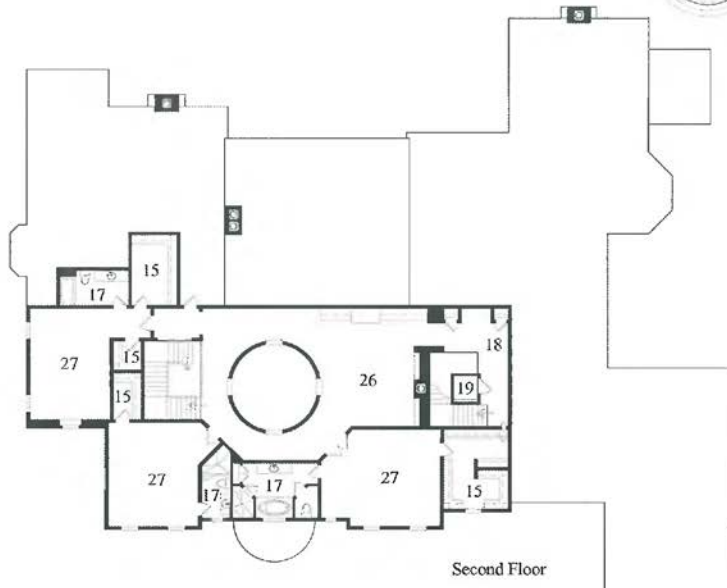

Second Floor

- |                |             |                 |                  |                    |                 |
|----------------|-------------|-----------------|------------------|--------------------|-----------------|
| 1 Foyer        | 6 Kitchen   | 11 Garage       | 16 Guest Bedroom | 21 Laundry         | 26 Sitting Area |
| 2 Living Room  | 7 Breakfast | 12 Master Suite | 17 Bath          | 22 Covered Porch   | 27 Bedroom      |
| 3 Dining Room  | 8 Office    | 13 His Bath     | 18 Stair Hall    | 23 Open Terrace    |                 |
| 4 Powder Room  | 9 Sitting   | 14 Her Bath     | 19 Elevator      | 24 Bar             |                 |
| 5 Keeping Room | 10 Rotunda  | 15 Closet       | 20 Pantry        | 25 Butler's Pantry |                 |



























# THE FAULK HOUSE

Atlanta, Georgia, 1997–1998

*Sheldon Simms, Builder*

*Interiors by Kim Davis*

What started out as an extensive remodel job turned into new construction when the existing foundation was found to be inadequate. However, the family decided to allow the original plan to guide the design of the new house. The result is an unusually charming and cozy arrangement that serves the family's needs. "We could have started from scratch, but we loved the plan that Bill Baker had designed, incorporating elements of the old house. Following Bill's inherent sense of scale and taste, the house was appropriately scaled for the lot. We are thrilled with the personality and surprises of the new house," relates Mr. Faulk.

Taking his cue from Dutch colonial architecture and Louisiana low-country houses, Mr. Baker combined elements from both in the Faulk house. The house's distinctive gambrel roof, with its Dutch dormers and inviting columned porch, looks as though it could have stood on this spot for generations. Built of aged fieldstone and wood shake, the house has a soft, weathered gray patina. Taking advantage of the property's steep topography, the house was designed with a two-story porch to integrate the building into the hillside.

Continuing the rustic theme in the home's interiors, natural materials frequently found in homes of the style were also used. The floors make use of antique heart-of-pine and some of the ceilings are plank board with box beams. "One of the most fun things we incorporated was the children's playroom over the garage," says Mrs. Faulk. "It's painted like a fairyland and has a hidden door to the children's bedrooms." Mr. Baker recounts, "The Faulks collaborated wonderfully and we all had a great time with the project. It's a home I love to return to time and again."











- |               |                  |                 |                        |          |
|---------------|------------------|-----------------|------------------------|----------|
| 1 Foyer       | 5 Screened Porch | 9 Laundry Room  | 13 Master Bath         | 17 Linen |
| 2 Study       | 6 Kitchen        | 10 Service Hall | 14 Closet              |          |
| 3 Dining Room | 7 Family Room    | 11 Garage       | 15 Bedroom             |          |
| 4 Powder Room | 8 Covered Porch  | 12 Master Suite | 16 Children's Playroom |          |



Front Elevation



Left Elevation



Right Elevation

















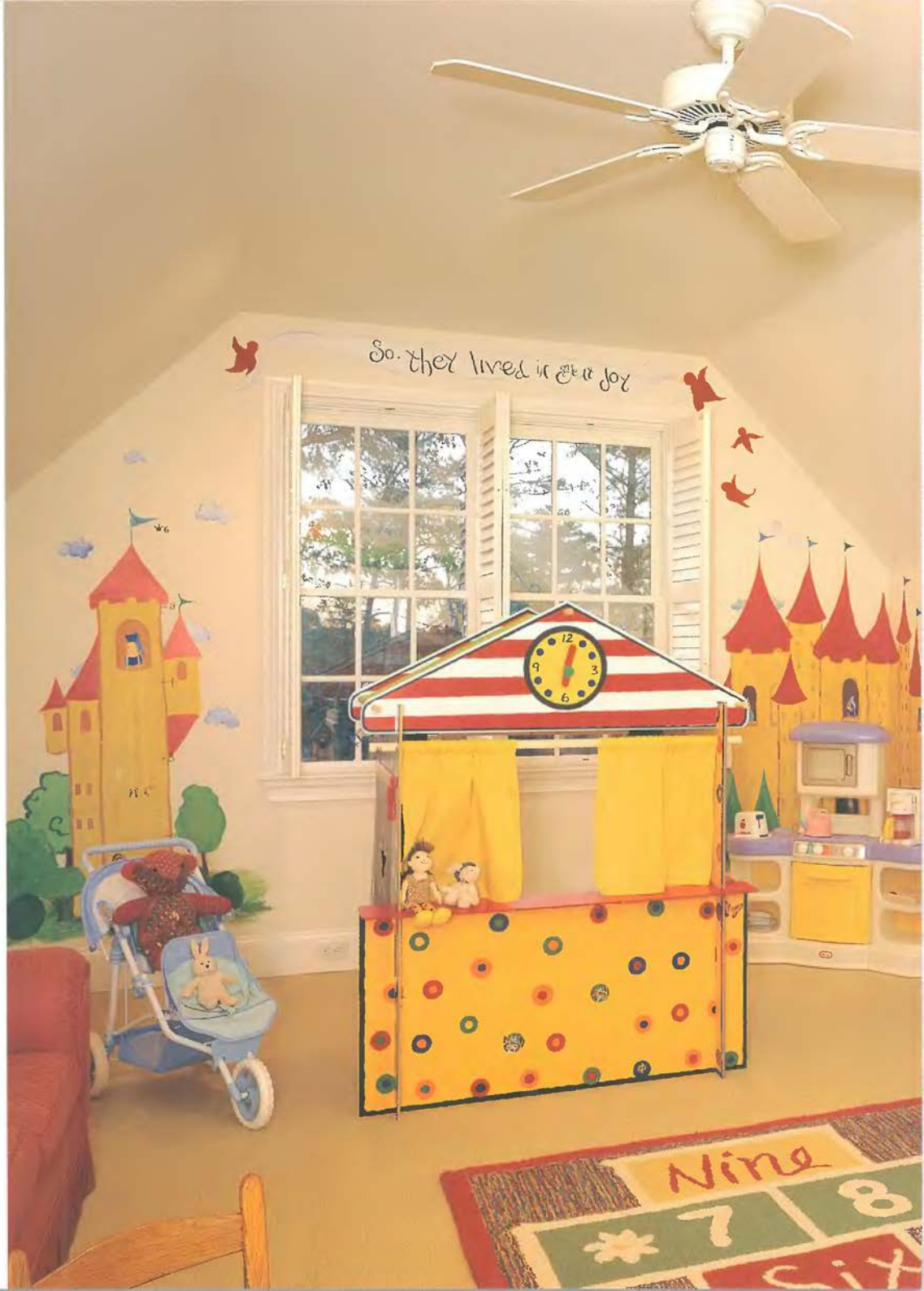

So they lived in joy



Nine

7

8

Six





# THE LEDBETTER HOUSE

Atlanta, Georgia, 1998–2000

*Sheldon Simms, Builder*

*Interiors by Nancy Warren*

The producers of HGTV's award-winning show *Before and After* contacted Bill Baker to submit a remodel project for filming and broadcast. He had the perfect house for the show. The long, low profile house had already been remodeled once in the 1980s, but was still architecturally unremarkable. With its high ceilings and generous floor plan, the house was an excellent candidate for additional remodeling.

The remodel began by adding an entire second floor to the existing home. "The extensive reframing allowed me to change the roofline and add the dormers and distinctive gables," says Mr Baker. The resulting house has a new stone veneer, a variegated slate roof, segmental French doors and casement windows. The interior floor plan, while needing only slight modification, was visually transformed by dramatic remodeling of the spaces in a country French vernacular.

Located just a block from the Governor's mansion, the property provides a beautiful setting for the house with its large trees and expansive lawns. "Because we wanted to focus on our teenagers and their friends, we needed a warm and welcoming house," says Mrs Ledbetter. "Bill designed a terrific recreation area upstairs for our girls to entertain large groups. It has become the perfect spot for us to meet the needs of many kids."



*Before*







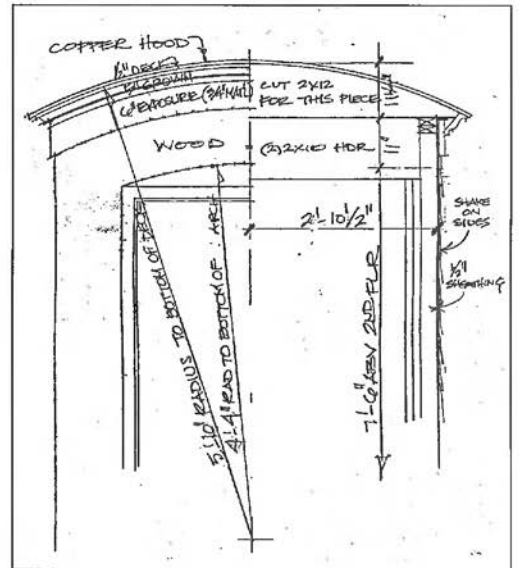
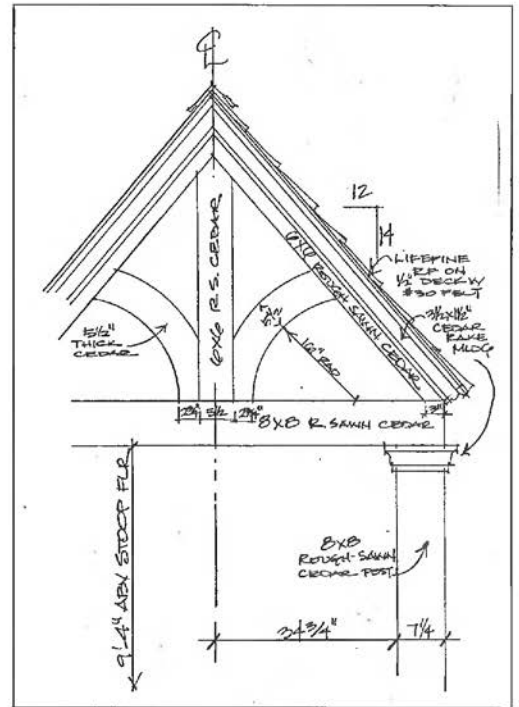
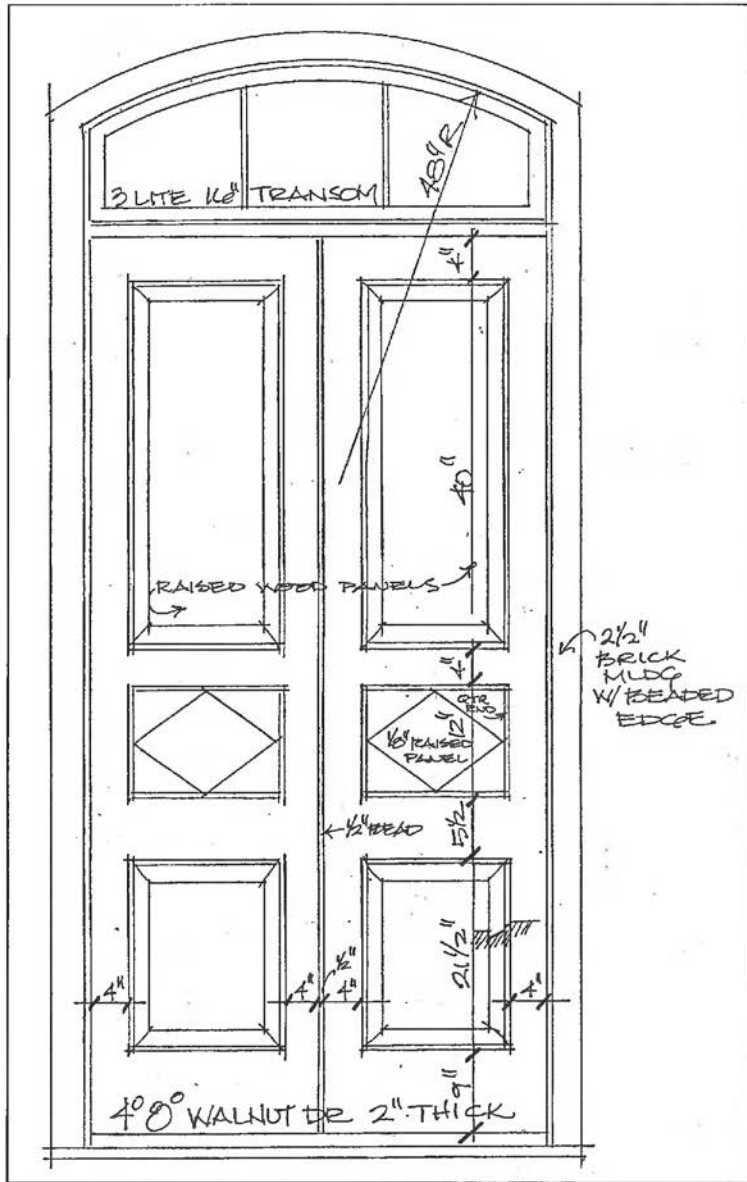

















# THE LOUDERMILK HOUSE

Atlanta, Georgia, 1998–2000

*Jerry Bonner, Builder*  
*Interiors by Jane Marsden*

A true American entrepreneur, Mr Loudermilk started renting folding chairs for 10 cents per day, after graduating from the University of North Carolina. What started as a modest furniture rental business, has grown to be a multinational business with annual rental and sales of over one billion dollars in over 850 stores across the United States, Canada, and Puerto Rico.

"Mr Loudermilk and his wife came to me with a special opportunity to design a Georgian-style house that was uniquely different," says Mr Baker. "Because the house was to be located at the intersection of two streets, I suggested the house should have two façades. In fact, the front portico and its three-story rotunda were designed to be the focal point for the intersection."

"They also wanted the floor plan to differ from the standard Georgian box. We designed the house in a V-shape. It's one of my most unusual plans and one that works well for entertaining large groups. Although the house is large at over 16,000 square feet, the interior rooms are still designed to be intimate and comfortable."

The Loudermilks have opened their grand house to more than 35 groups, both political and charitable. "We've enjoyed sharing the house with the community," says Mrs Loudermilk. "We built the house to be used and that's exactly what we've done. It's a pleasure seeing it filled with people enjoying themselves."







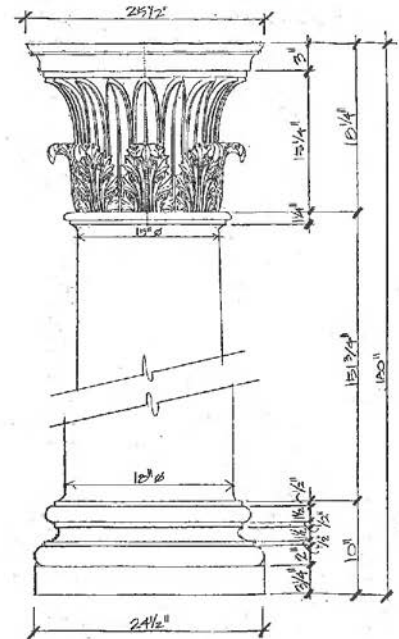
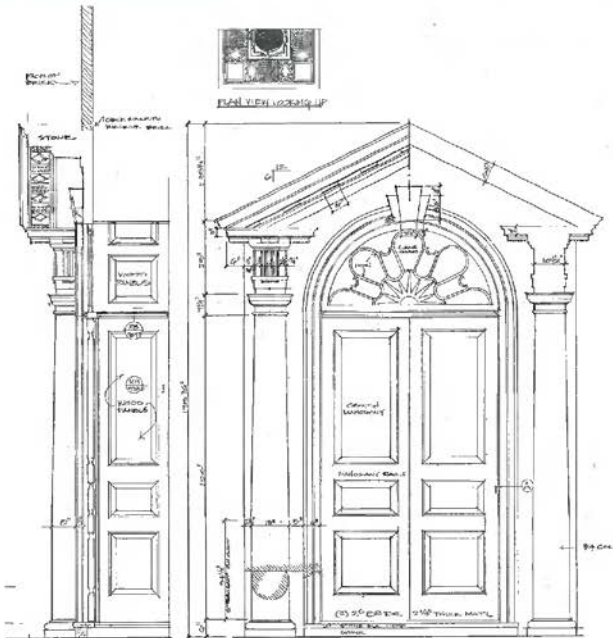

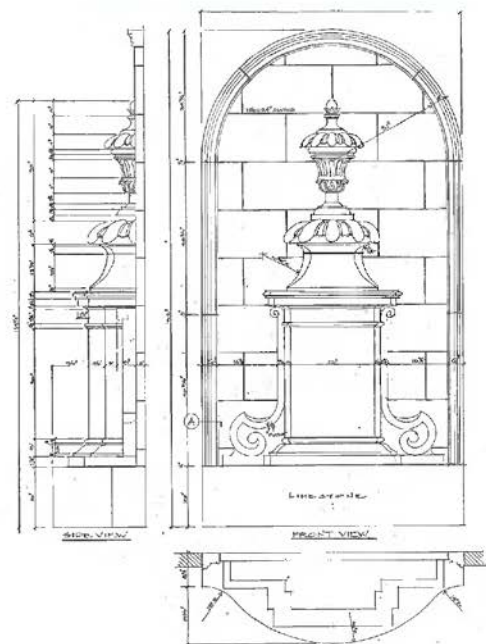
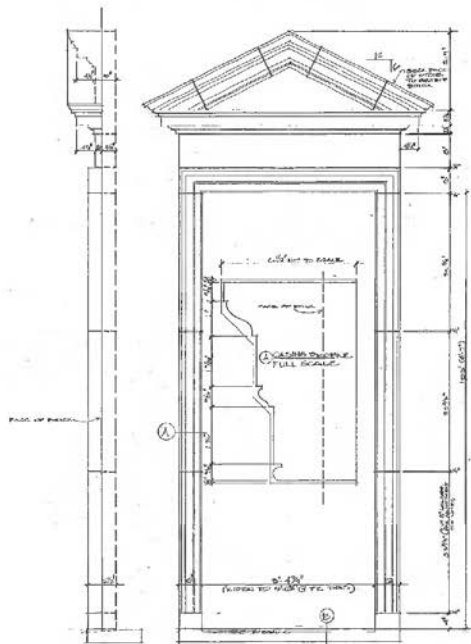
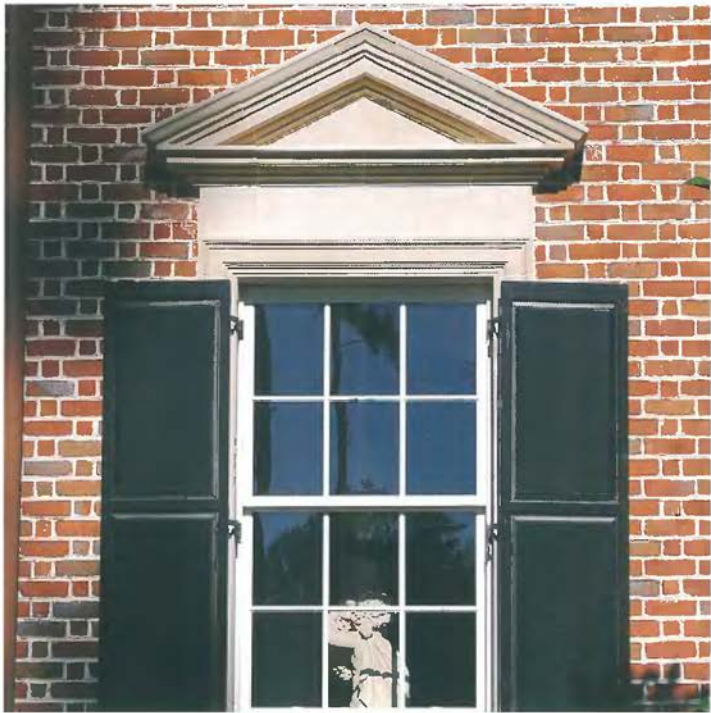





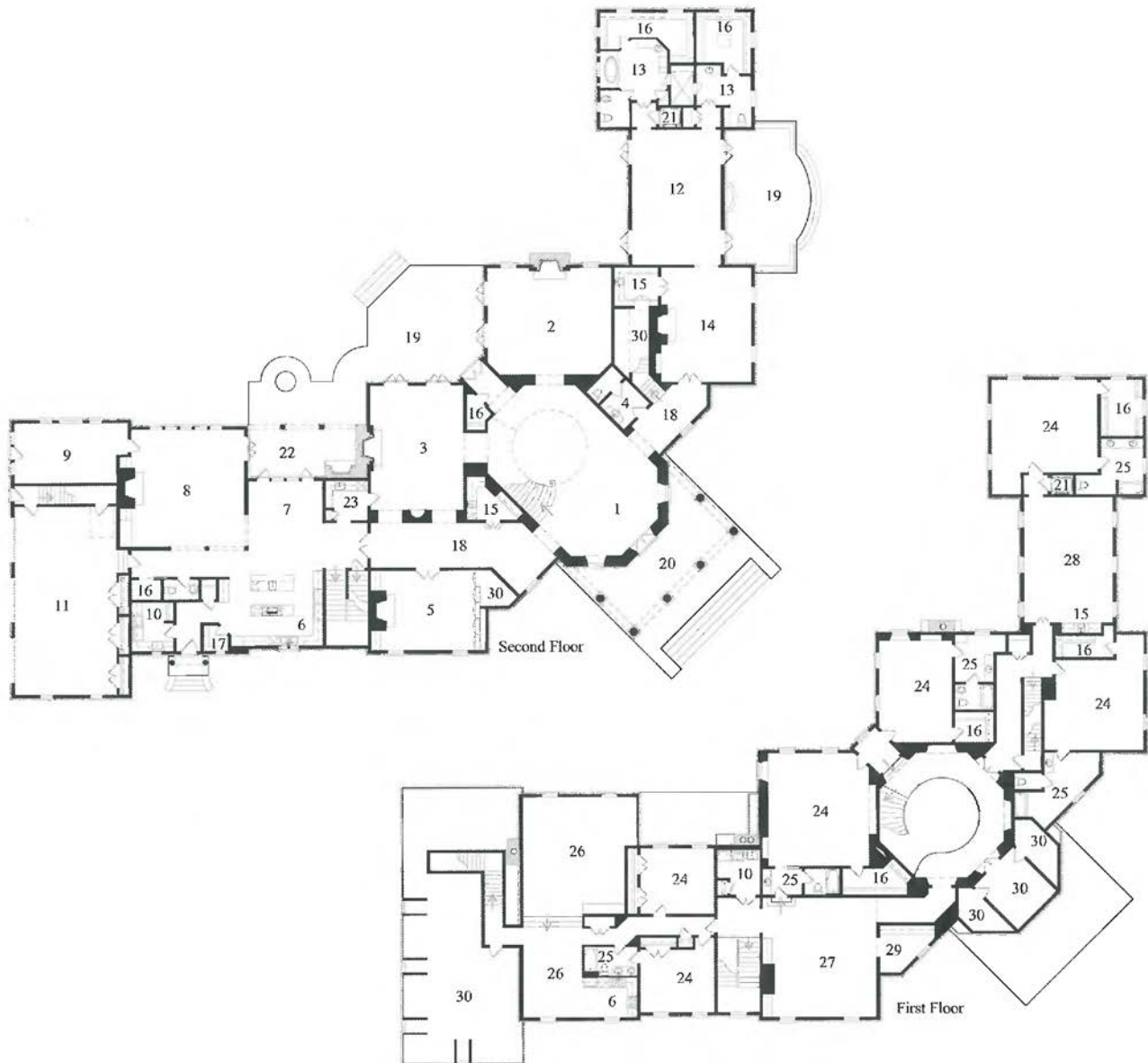

- |                 |                 |                 |            |                    |                  |
|-----------------|-----------------|-----------------|------------|--------------------|------------------|
| 1 Foyer         | 6 Kitchen       | 11 Garage       | 16 Closet  | 21 Elevator        | 26 Guest Suite   |
| 2 Living Room   | 7 Breakfast     | 12 Master Suite | 17 Pantry  | 22 Covered Porch   | 27 Game Room     |
| 3 Dining Room   | 8 Keeping Room  | 13 Master Bath  | 18 Gallery | 23 Butler's Pantry | 28 Media Room    |
| 4 Powder Room   | 9 Exercise      | 14 Sitting      | 19 Terrace | 24 Bedroom         | 29 Computer Room |
| 5 Paneled Study | 10 Laundry Room | 15 Wet Bar      | 20 Portico | 25 Bathroom        | 30 Storage       |































# THE SIEGEL HOUSE

Atlanta, Georgia, 1999–2001

*McGarrity-Garcia Residential, Builder*  
*Interiors by Susan Bozeman*

When Mr Siegel came to Atlanta as President of Turner Network Television, he and his family wanted to build a home with some of the same New England charm found in their community along the Long Island Sound in New York. "The house we were coming from had a view of the Sound and our neighborhood was like a slice out of old New England. We wanted our new home to recapture some of this charm and warmth," says Mr Siegel.

Enlisting the help of Bill Baker, the Siegels' house, with its gambrel roof, Dutch dormers and inviting porches achieves the look and feel desired by the family. "We incorporated weathered wood and stone to give the house a lived-in feel," says Mr Baker. Among the house's special features is a home office which has been treated to look like a rustic Montana lodge. In addition, each of the principal first-floor rooms have special finishes such as plank board walls, aged beamed ceilings or flagstone floors.

"When I am at home in my office, I can see the number of people who stop and look at our house from the street," says Mr Siegel. "There is something about this house that captures people's imaginations. I think it's because people at all levels can relate to our house in scale and form. It's a house that others feel like they could live in too because there is nothing pretentious about it. It is a great family home."











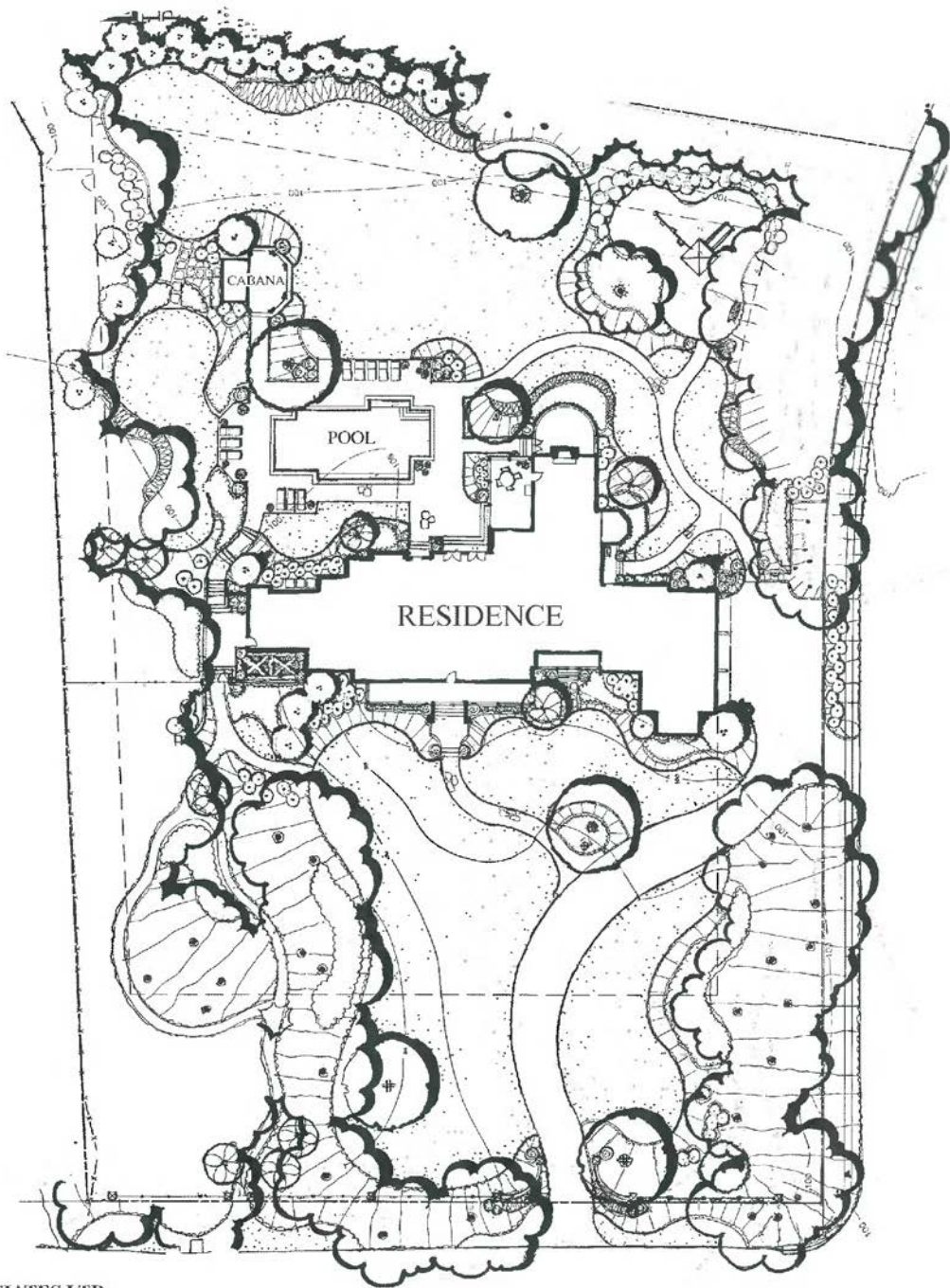

LAND PLUS ASSOCIATES LTD.  
LANDSCAPE ARCHITECTS



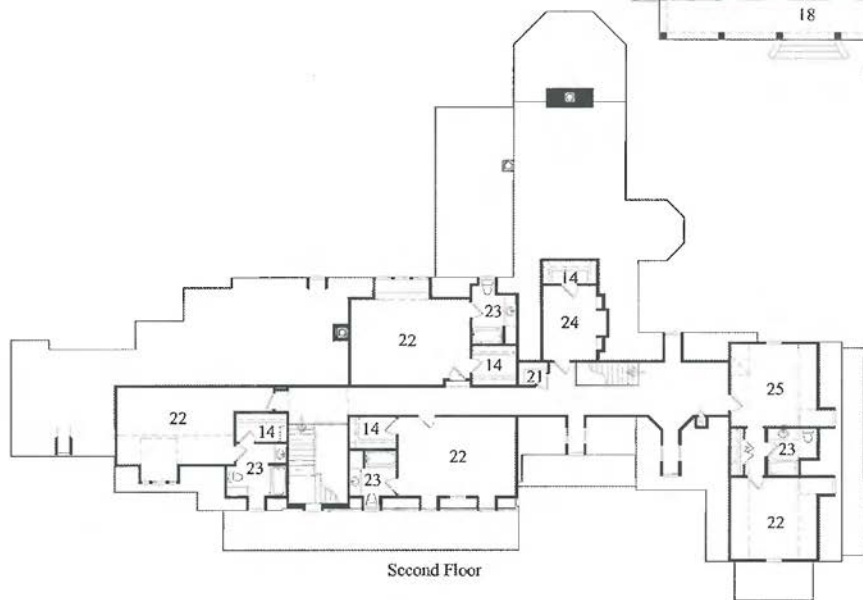
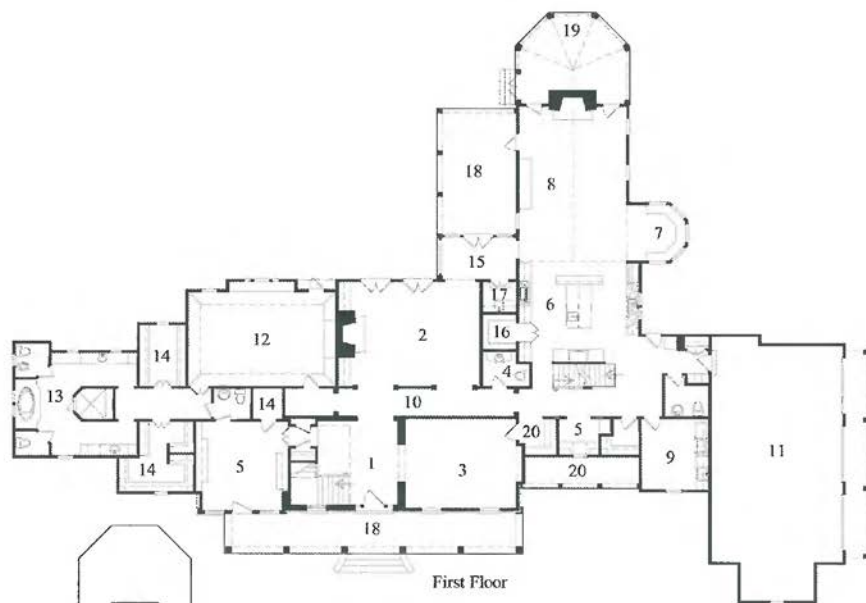

- 1 Foyer
- 2 Living Room
- 3 Dining Room
- 4 Powder Room
- 5 Office

- 6 Kitchen
- 7 Breakfast
- 8 Keeping Room
- 9 Laundry Room
- 10 Gallery

- 11 Garage
- 12 Master Suite
- 13 Master Bath
- 14 Closet
- 15 Vestibule

- 16 Pantry
- 17 Bar
- 18 Covered Porch
- 19 Screened Porch
- 20 Butler's Pantry

- 21 Linen
- 22 Bedroom
- 23 Bathroom
- 24 Media Room
- 25 Sitting

















# THE LABRIOLA HOUSE

Griffin, Georgia, 1998–2000

*Randy Chandler, Builder*

*Interiors by J. Newton Bell, Jr.*

The family's historical connection to Spalding County dates back to the original 1836 federal land grant to General Lewis Griffin. It was his 800-acre railroad terminus that would one day become the town of Griffin, Georgia. Thus the family's historical connection to the county dates back to its origins.

Over the years, each successive generation has sold off or split up their property interests. "We have always loved the country and have been fortunate to have been able to consolidate certain family interests and retain this 100 acres," says Mrs LaBriola.

Inspired by the land's English countryside appearance, Mr Baker located the large Georgian-style home at the end of a 1,500-foot-long driveway lined with Sycamore trees. "In a few years, the trees lining the approach will have filled in. It's going to be even more fabulous," says Mr Baker.

In designing the home, Mr Baker drew upon classic Palladian three-part designs for his inspiration. "We wanted a house that was perfectly symmetrical and that took advantage of being on a large tract of land. Bill Baker is incredibly talented and exceeded our expectation," says Mr LaBriola.

The family wanted a Georgian-style home combining brick and limestone. "Bill showed us a number of examples and we especially liked the look of the limestone pilasters with Ionic capitals," says Mr LaBriola. "Several other elements on the front façade had their inspiration from examples found in the work of Shutze and Reid from a generation earlier. I am gratified that we did justice to this unique property with an equally distinctive house."







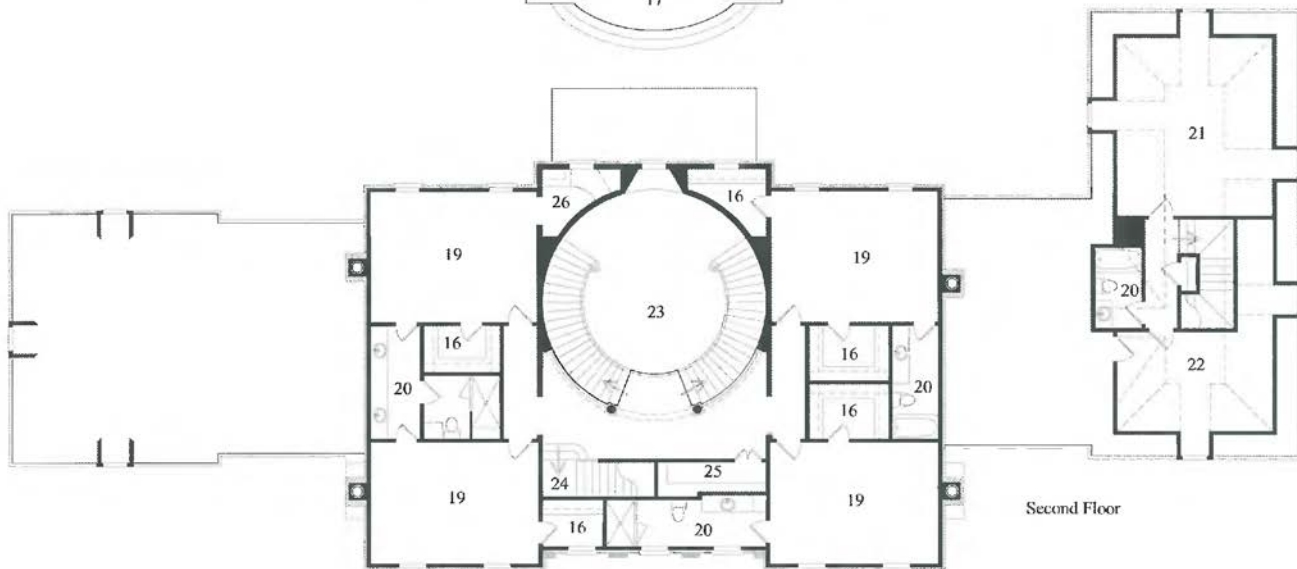
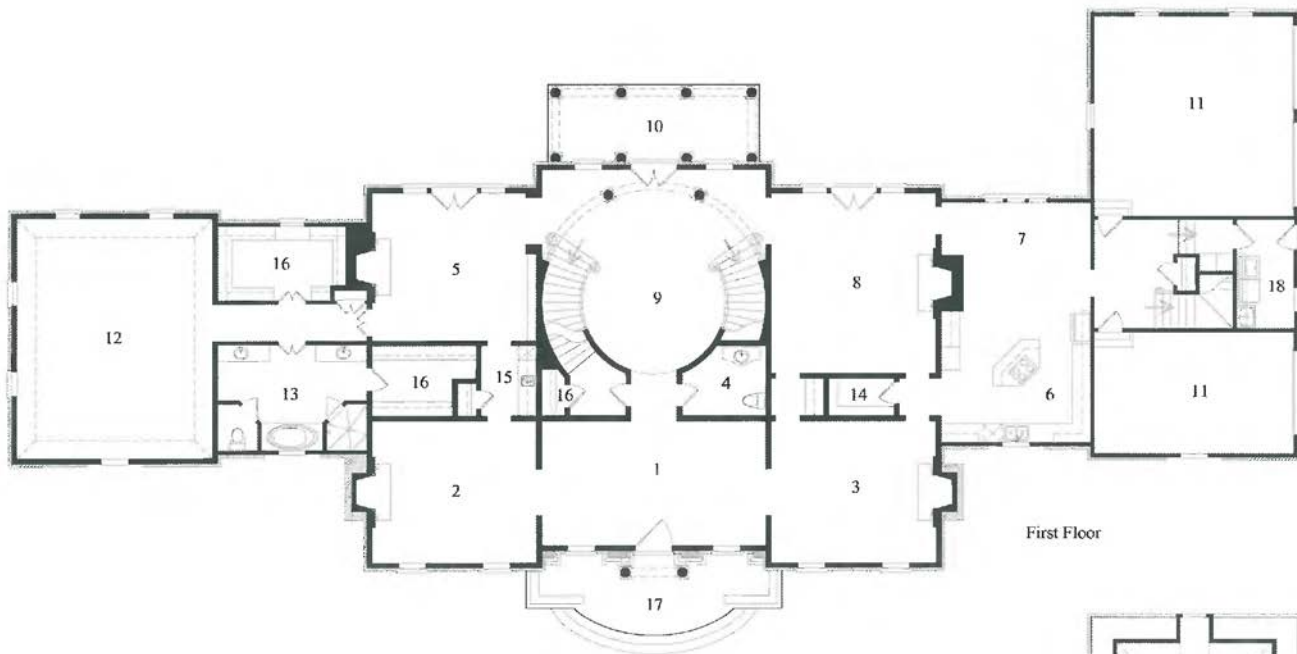

- |               |               |                 |                 |                  |               |
|---------------|---------------|-----------------|-----------------|------------------|---------------|
| 1 Foyer       | 6 Kitchen     | 11 Garage       | 16 Closet       | 21 Office        | 26 Study Area |
| 2 Living Room | 7 Breakfast   | 12 Master Suite | 17 Terrace      | 22 Bonus Room    |               |
| 3 Dining Room | 8 Family Room | 13 Master Bath  | 18 Laundry Room | 23 Open to Below |               |
| 4 Powder Room | 9 Rotunda     | 14 Pantry       | 19 Bedroom      | 24 Attic Stair   |               |
| 5 Library     | 10 Veranda    | 15 Wet Bar      | 20 Bathroom     | 25 Linen         |               |





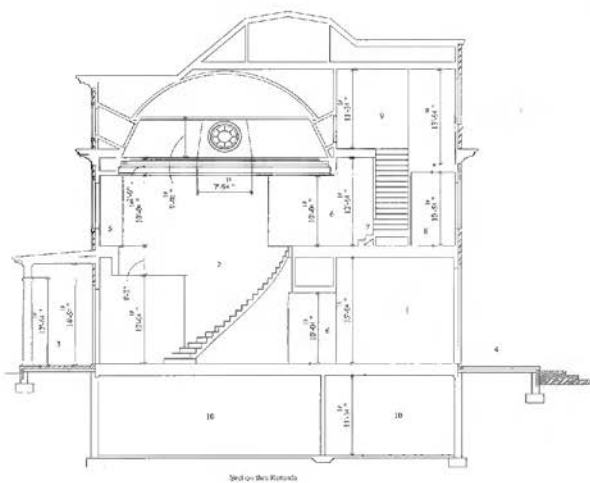

- |           |                     |
|-----------|---------------------|
| 1 Foyer   | 6 Hall              |
| 2 Rotunda | 7 Attic Stair       |
| 3 Veranda | 8 Bathroom          |
| 4 Terrace | 9 Attic Storage     |
| 5 Shelf   | 10 Basement Storage |













# THE ALLEN HOUSE

Nashville, Tennessee, 1998–2000

*Ramsey-Daugherty, Builder*

*Interiors by Landy Gardner*

"The Allen's house has a special place in my heart because it is located in my hometown of Nashville," remarks Mr Baker. The English-style home with its clinker brickwork and terra cotta tile roof is one of Bill Baker's best examples in the style. Built in one of Nashville's most established neighborhoods, the design goal of the house was to blend in and to enhance a street known for its beautiful old homes.

"We had fun on the project because the Allens wanted to use all the right materials and finishes," says Mr Baker. "The builder took the time to get the details right, and it shows. Whether it's the carved staircase, the gothic arches, or the linen fold panels in the front door, Jay made sure every detail was properly executed."

"Landy Gardner was also in tune with the architecture. His selections of colors, fabrics, and furnishings are a wonderful compliment to the home's architecture," says Mr Baker. "The whole team worked well together and the home, as you can see, is a dramatic success."









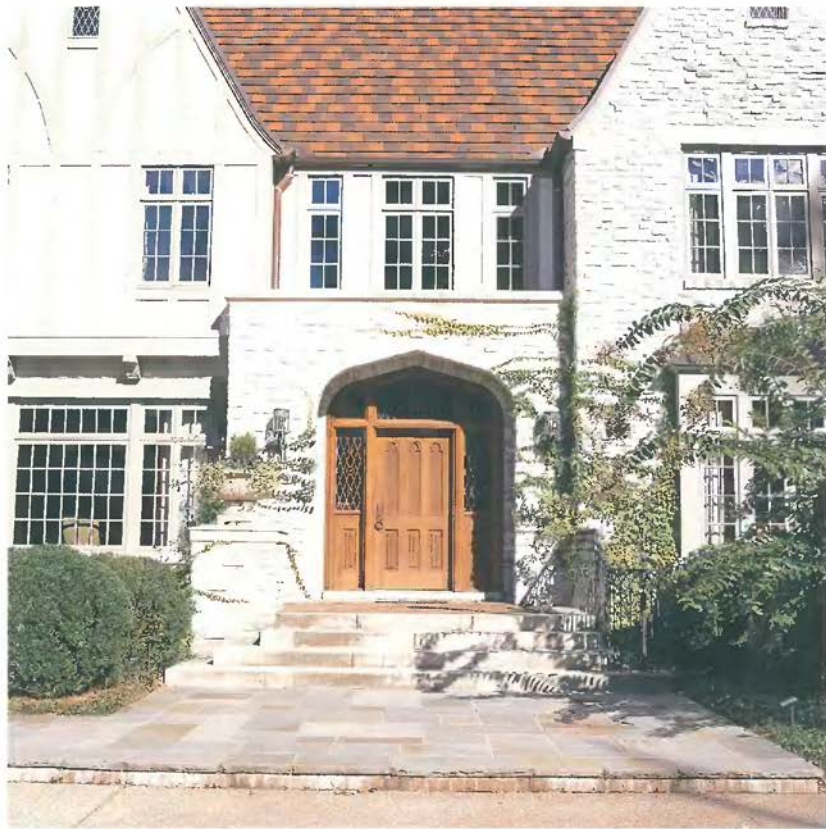











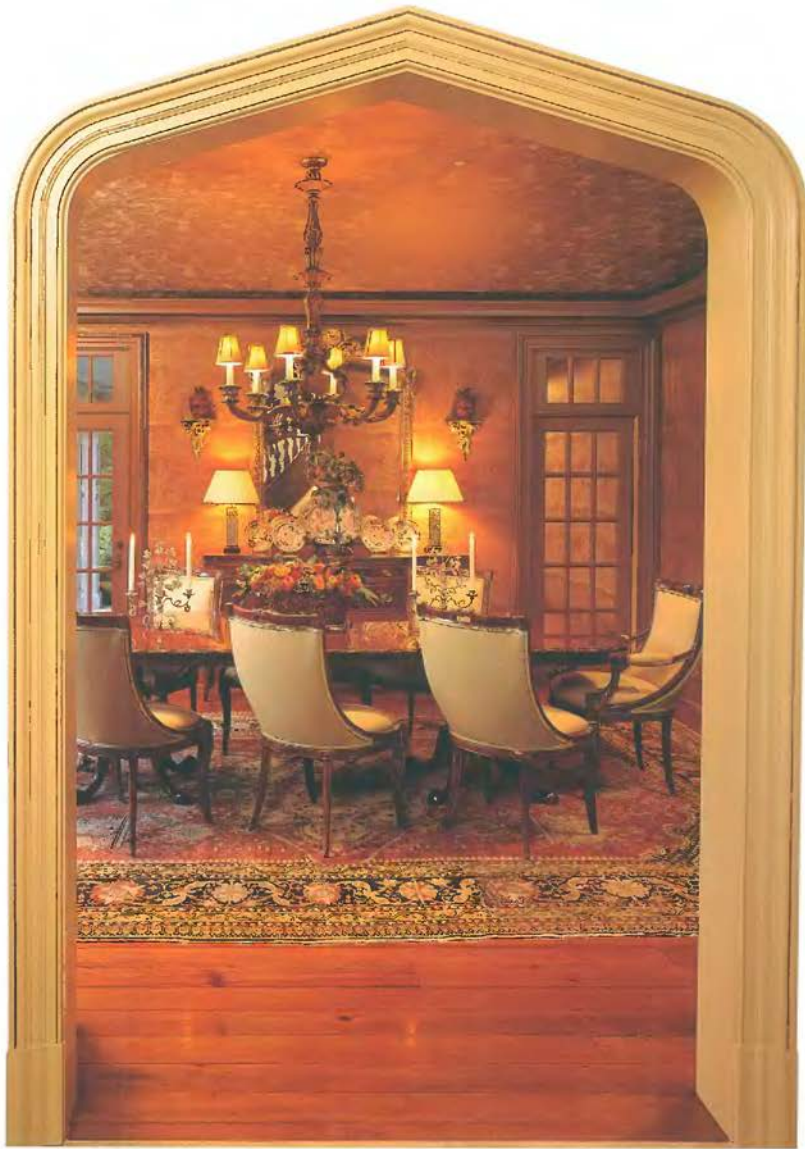







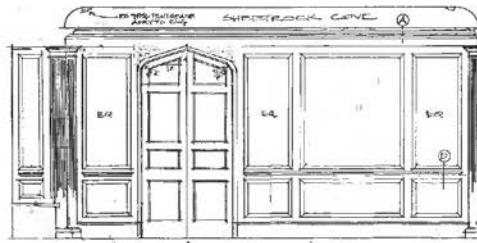

ELEVATION TOWARD TOWER  
 $\frac{1}{2}'' = 1'-0''$

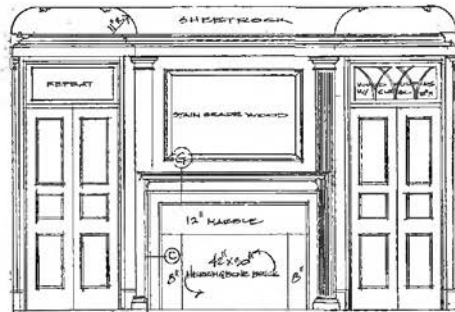

ELEVATION TOWARD FP  
 $\frac{1}{2}'' = 1'-0''$

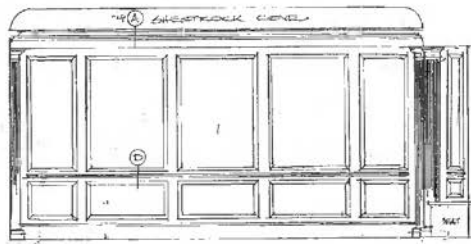

ELEVATION TOWARD SIDE WALL  
 $\frac{1}{2}'' = 1'-0''$

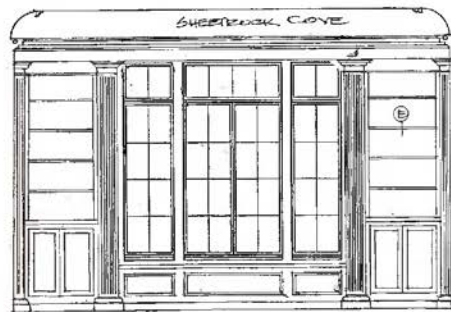

ELEVATION TOWARD HWY  
 $\frac{1}{2}'' = 1'-0''$







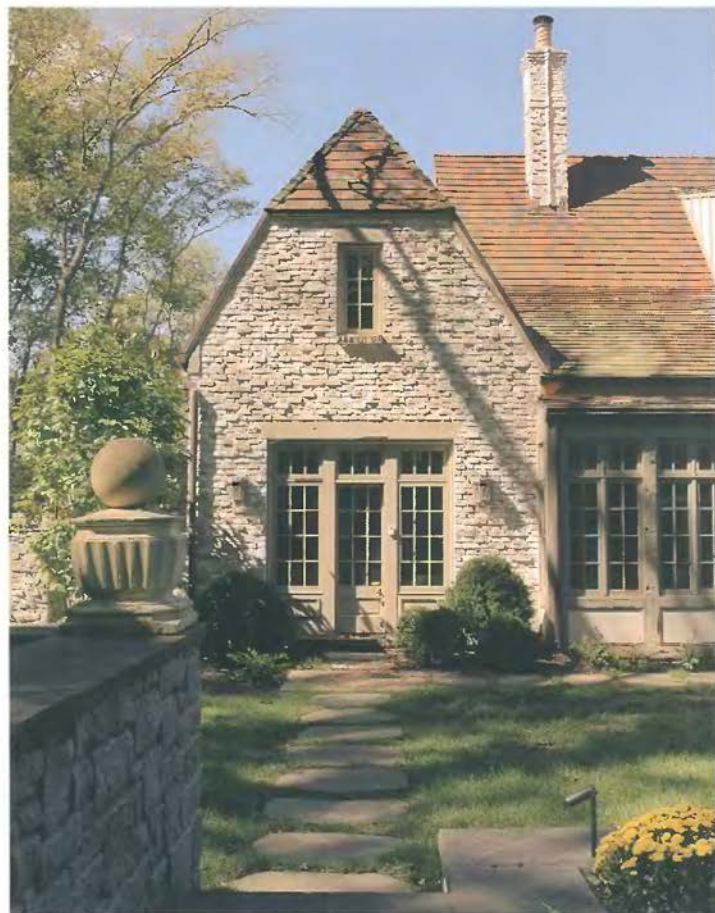



# THE HIMOT HOUSE

Atlanta, Georgia, 2000–2001

*McGarrity-Garcia Residential, Builder*  
*Interiors by Susan Bozeman Designs*

When the Himots first met with Bill Baker, they knew the relationship would be a good one. “We brought him photos of houses we liked and many of them were houses Bill had designed,” remembers Dr Himot. “It was perfect harmony. I was amused that he had many of the same photos and clippings in his own files. He had an immediate understanding of what we wanted.”

The Himots acquired a large parcel of land and wished to build a handsome Georgian-style home incorporating wood-molded brick and limestone. The elegant open plan, with its two-story entrance hall and curved staircase with iron railing achieves an easy elegance. “We didn’t fully appreciate what Bill had designed until the interior moldings were installed,” says Mrs Himot. “The best surprise was the wonderful detailing in the foyer. It was difficult for us to fully appreciate what was planned by just looking at the drawings. We had to see it built.”

Behind the house is an elliptical lawn with a swimming pool and Georgian-style pool house. The symmetry of the rear façade is quickly apparent looking back at the house from across the pool. “One of our favorite views is the rear of the house. There aren’t many houses where the back is as attractive as the front,” says Dr Himot. “The architecture has been a delight for our eyes.”







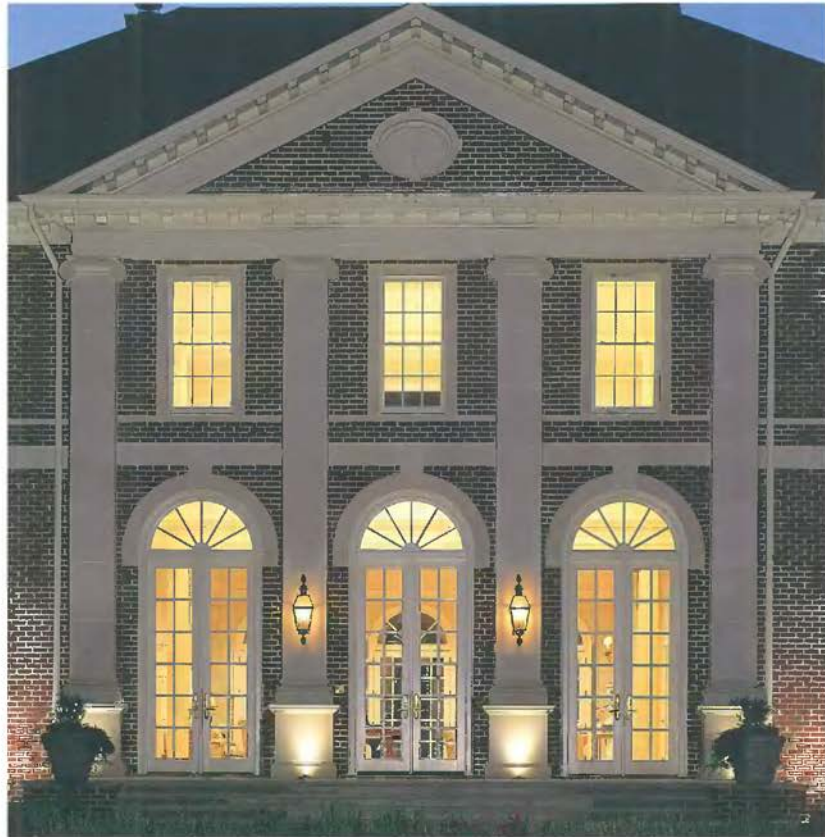

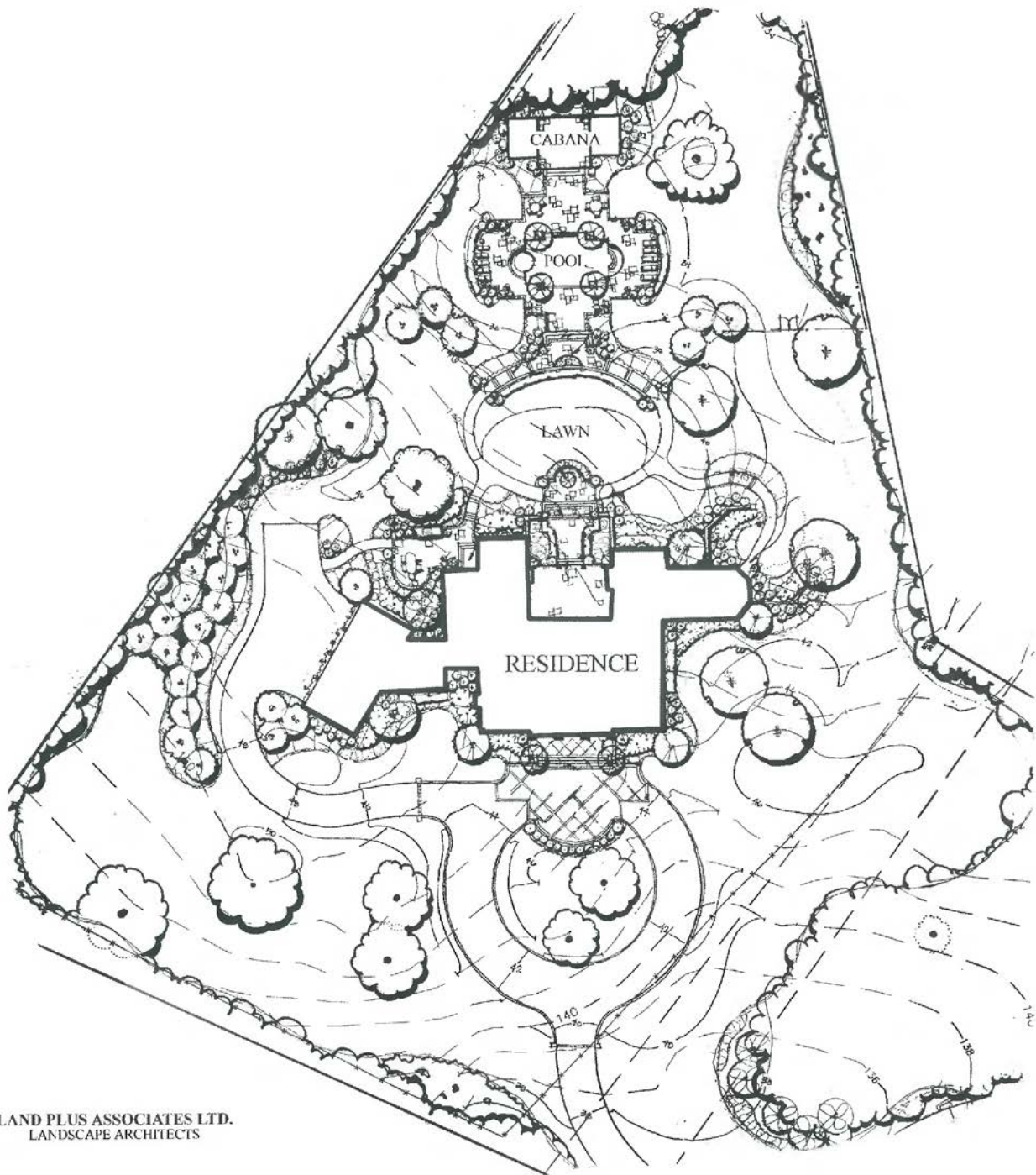

LAND PLUS ASSOCIATES LTD.  
LANDSCAPE ARCHITECTS



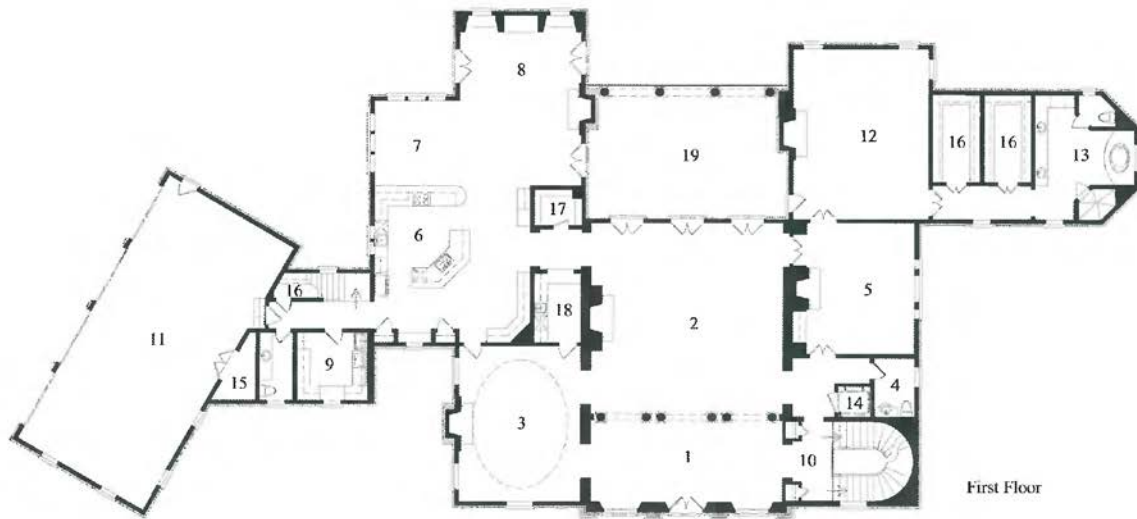

First Floor

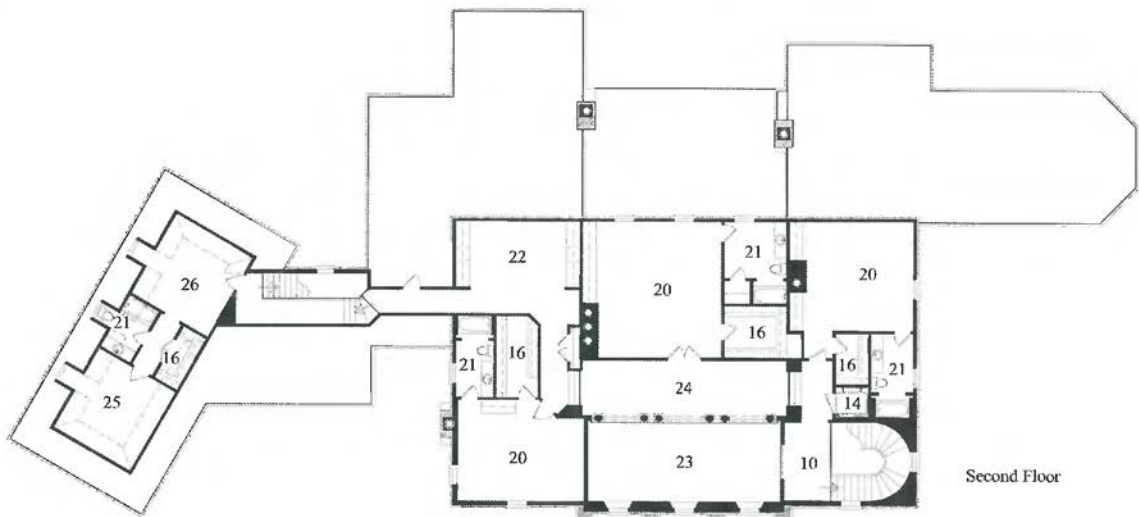

Second Floor

- |               |                |                 |            |                  |            |
|---------------|----------------|-----------------|------------|------------------|------------|
| 1 Foyer       | 6 Kitchen      | 11 Garage       | 16 Closet  | 21 Bathroom      | 26 Sitting |
| 2 Living Room | 7 Breakfast    | 12 Master Suite | 17 Pantry  | 22 Study         |            |
| 3 Dining Room | 8 Keeping Room | 13 Master Bath  | 18 Wet Bar | 23 Open to Below |            |
| 4 Powder Room | 9 Laundry Room | 14 Elevator     | 19 Loggia  | 24 Balcony       |            |
| 5 Library     | 10 Stair Hall  | 15 Storage      | 20 Bedroom | 25 Guest Suite   |            |





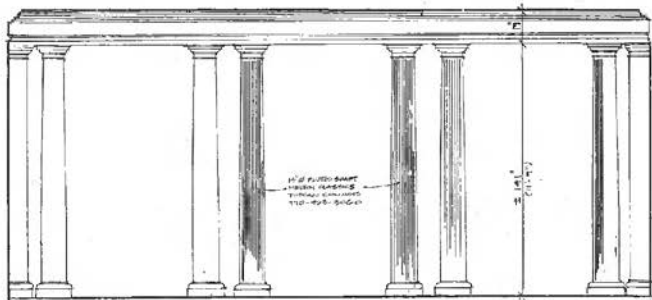

LIVING ROOM TOWARD FOYER.  
1/2" = 1'-0"

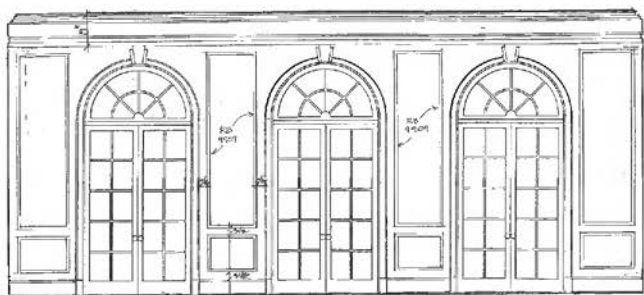

LIVING ROOM TOWARD REAR.  
1/2" = 1'-0"

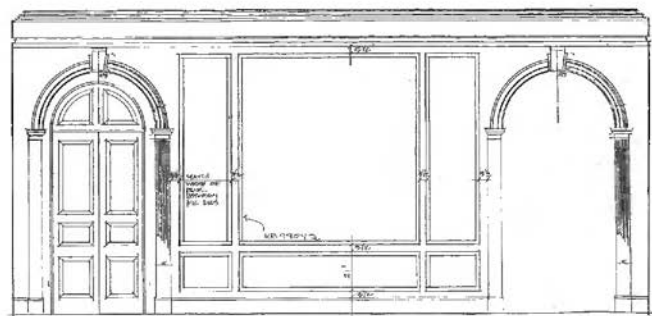

LIVING ROOM TOWARD LIBRARY.  
1/2" = 1'-0"

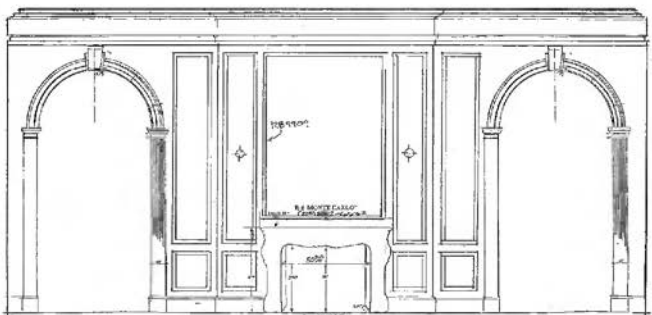

LIVING ROOM TOWARD.  
1/2" = 1'-0"











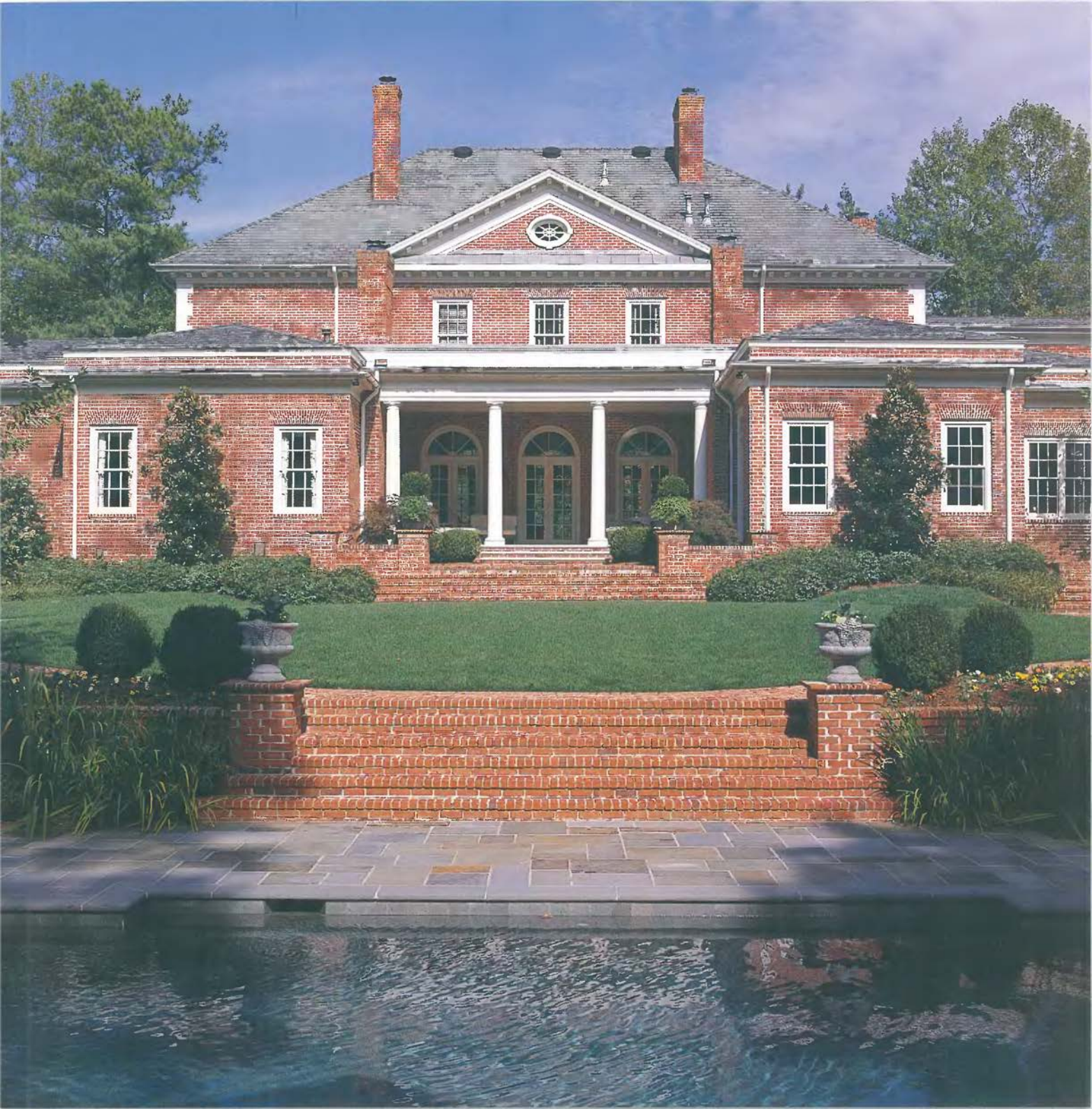



# THE BURFITT HOUSE

Atlanta, Georgia, 2000–2003

*McGarrity-Garcia Residential, Builder*  
*Interiors by Susan Bozeman Designs*

When Mr Burfitt's business brought him to Atlanta, he and his wife originally looked at a location far to the north of city. "But Bill Baker suggested that we look at a piece of property closer to Atlanta that he knew about. It was so heavily wooded it was hard to evaluate, but Bill had the vision," relates Mr Burfitt. "It was such a wilderness. We even saw fox and deer on the property—and we were just a few miles from downtown! Ultimately though, we took his advice and bought here instead."

The property was once part of a large Atlanta estate of over 500 acres. Over the years it was sold off and this was the last remaining piece. The original estate house, located next door, was designed by Philip Shutze, one of America's greatest classical architects. The architectural and historical heritage of the property was great and the new house had to meet the challenge.

"Because this was the fifth home they had built during their married life, the Burfitts were very organized and informed about the building process," recalls Mr Baker. "We had the best time together designing this house. They were enthusiastic about my ideas and we collaborated well."

Mr Burfitt recounts, "Bill took our ideas and desires and incorporated them in the plans while remaining true to the style. Working with him was a real pleasure."







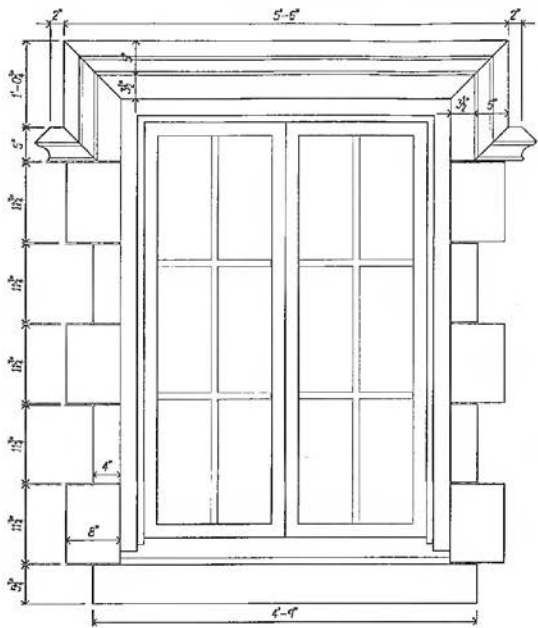

W-5  
 WINDOW SURROUND DETAIL  
 SCALE OF 1" EQUALS 1'-0"







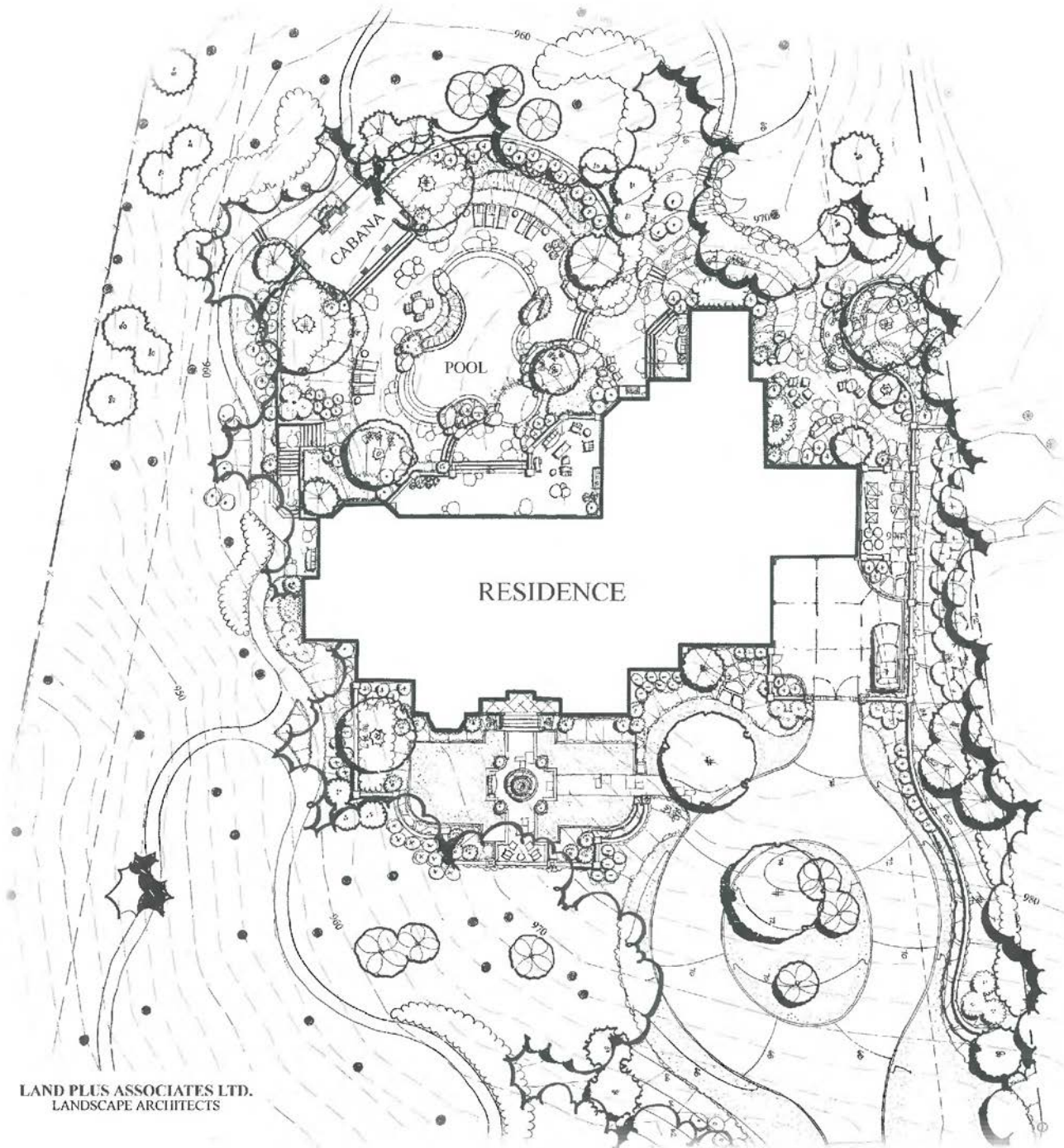

LAND PLUS ASSOCIATES LTD.  
LANDSCAPE ARCHITECTS





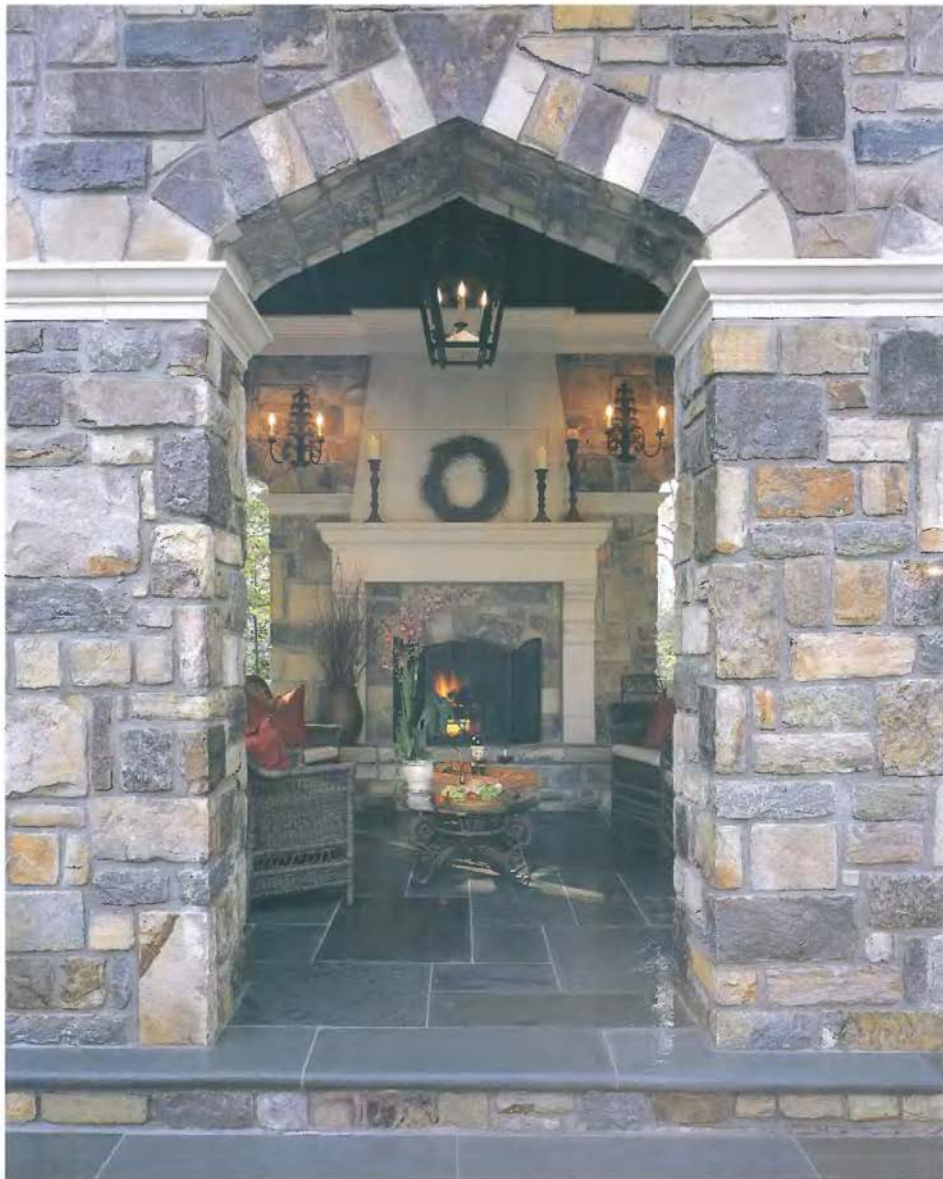

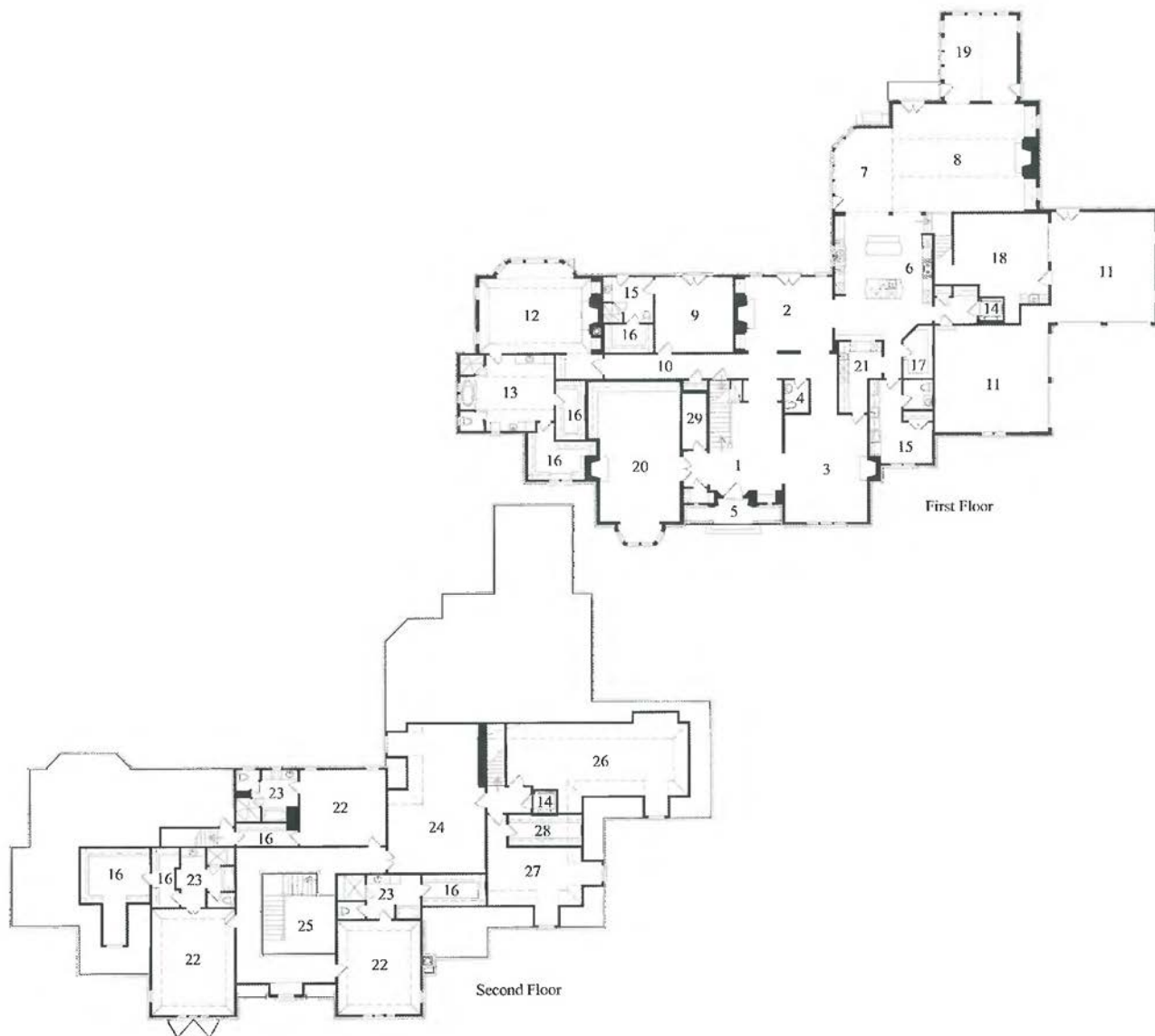

- |               |                |                 |                     |                    |                   |
|---------------|----------------|-----------------|---------------------|--------------------|-------------------|
| 1 Foyer       | 6 Kitchen      | 11 Garage       | 16 Closet           | 21 Butler's Pantry | 26 Storage        |
| 2 Living Room | 7 Breakfast    | 12 Master Suite | 17 Pantry           | 22 Bedroom         | 27 Hobby Room     |
| 3 Dining Room | 8 Keeping Room | 13 Master Bath  | 18 Workshop         | 23 Bathroom        | 28 Cedar Closet   |
| 4 Powder Room | 9 Guest Suite  | 14 Elevator     | 19 Sun Porch        | 24 Den             | 29 Equipment Room |
| 5 Terrace     | 10 Gallery     | 15 Laundry      | 20 Media Room/Study | 25 Open to Below   |                   |









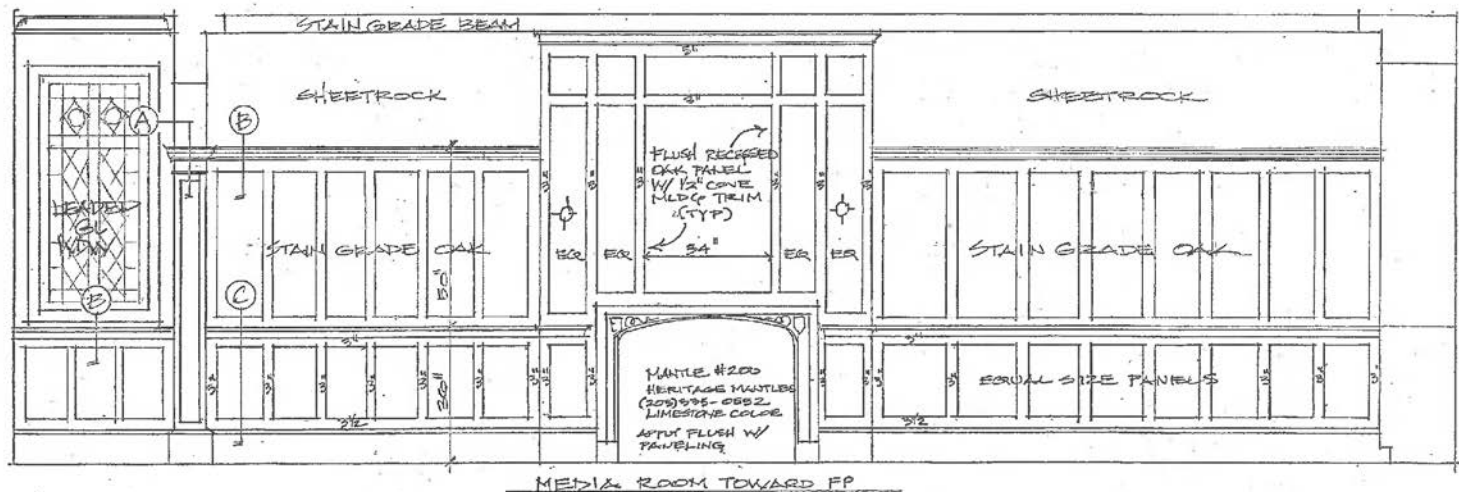











# THE CLARE HOUSE

Atlanta, Georgia, 2000–2002

*Peachtree Group, Builder*

*Interiors by Dilger-Gibson*

Dr Clare, a bachelor at the time, bought two nondescript houses, side by side, near one of Atlanta's best private golf courses. He lived in one and rented out the other for a number of years. "After I married, we decided to demolish the houses and use both lots," says Dr Clare. The combined property is one of the largest estate lots near the golf course.

The resulting house was inspired by a number of eclectic old-world design elements. With its octagonal turret and aged stonework, the house presents an inviting appearance from the long driveway. The open arch of the porte-cochère connects the garage with the house and provides an interesting break in the façade. The iron railings, made by Ludvik Cherny, a European-trained craftsman, add to the charm of the house.

The main staircase follows the curve of the octagonal turret and frames the starburst detail in the foyer floor. The elaborate ironwork is repeated in the railing of the living room balcony. Other materials and finishes of interest are the aged French limestone paved floors in the foyer and the antique heart-of-pine, mixed with herringbone brick, used in the kitchen.

"The house is full of fun details that continue to delight us," says Mrs Clare. "For instance, one of our favorite details is the medallion in the floor of the porte-cochère that contains our initials and the date of the house. Also, the house flows perfectly for entertaining. Its design and finishes have provided us with the warmth, light and intimate spaces that make it a real dream home in which to raise our family."

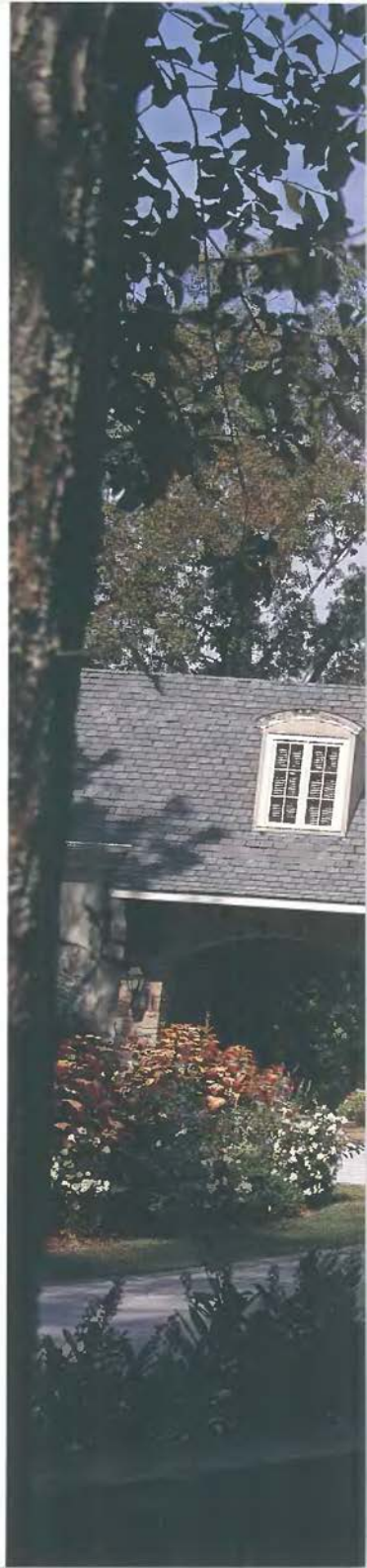









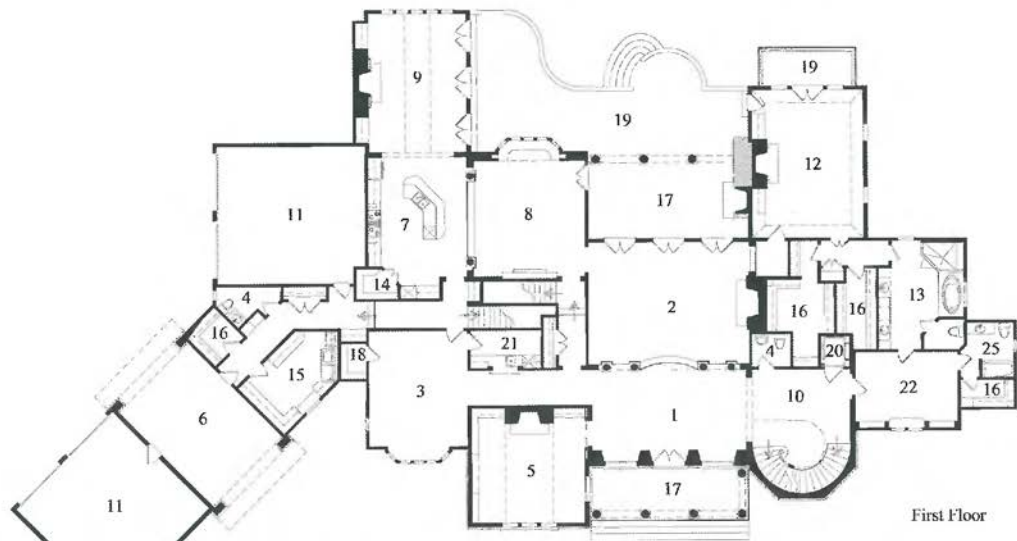

First Floor



Second Floor

- |                 |                 |                  |                  |                     |
|-----------------|-----------------|------------------|------------------|---------------------|
| 1 Foyer         | 7 Kitchen       | 13 Master Bath   | 19 Terrace       | 25 Bath             |
| 2 Living Room   | 8 Breakfast     | 14 Pantry        | 20 Elevator      | 26 Upstairs Sitting |
| 3 Dining Room   | 9 Keeping Room  | 15 Laundry       | 21 Wet Bar       | 27 Linen            |
| 4 Powder Room   | 10 Stair Hall   | 16 Closet        | 22 Nursery       |                     |
| 5 Study         | 11 Garage       | 17 Covered Porch | 23 Open to Below |                     |
| 6 Porte Cochere | 12 Master Suite | 18 China Closet  | 24 Bedroom       |                     |









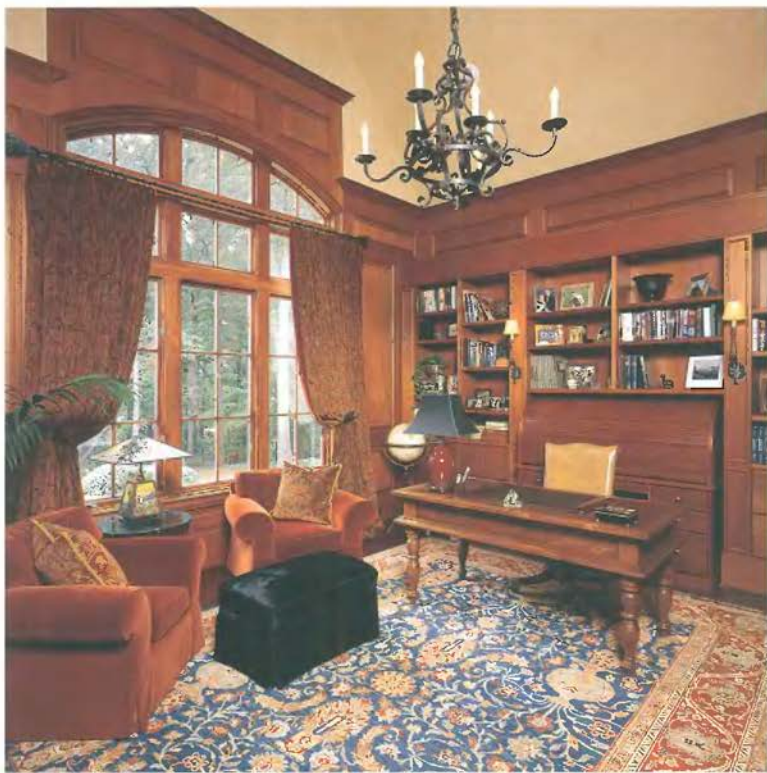





















# THE ROESENER HOUSE

Las Vegas, Nevada, 2000–2003

*R. W. Bugbee and Associates, Builder*

*Interior Consultation by Lady Henrietta Spencer-Churchill*

After spending several summers in Ireland, and eventually having the opportunity to restore an 18th-century country home, the Roeseners decided to recreate that experience when they built their primary residence in Las Vegas. The design of their new home was guided by their respect for classical architecture, an appreciation for detail, and a high regard for fine craftsmanship.

"I contacted Bill Baker after reading an article in *Traditional Home* magazine about his work in the classical manner," says Mrs Roesener. "During our initial meeting, I described floor by floor the home I wanted to build. He immediately understood what I was describing, and the next day presented us with preliminary drawings. Those first sketches were essentially what we built."

"The challenge was to design a Georgian-style home that would not look out of place in the desert conditions of Las Vegas," says Mr Baker. "The key was to use stucco instead of brick, natural stone trim, and a slate roof instead of the typical terra cotta tile. The resulting house remains true to its style while blending with the colors and materials of the community."

The home's interiors are authentic to the period and provide a perfect background for the Roeseners' collection of art and antiques. The 28-inch-thick walls, 12-foot ceilings, and paneled wainscoting and window jambs, along with the proportions and details of the rooms, give the impression of an authentic Georgian-period building. "Every time I walk into our home, I appreciate the dignity and integrity of Georgian architecture. I am so pleased that we took the time and effort to build our dream home," states Mrs Roesener.



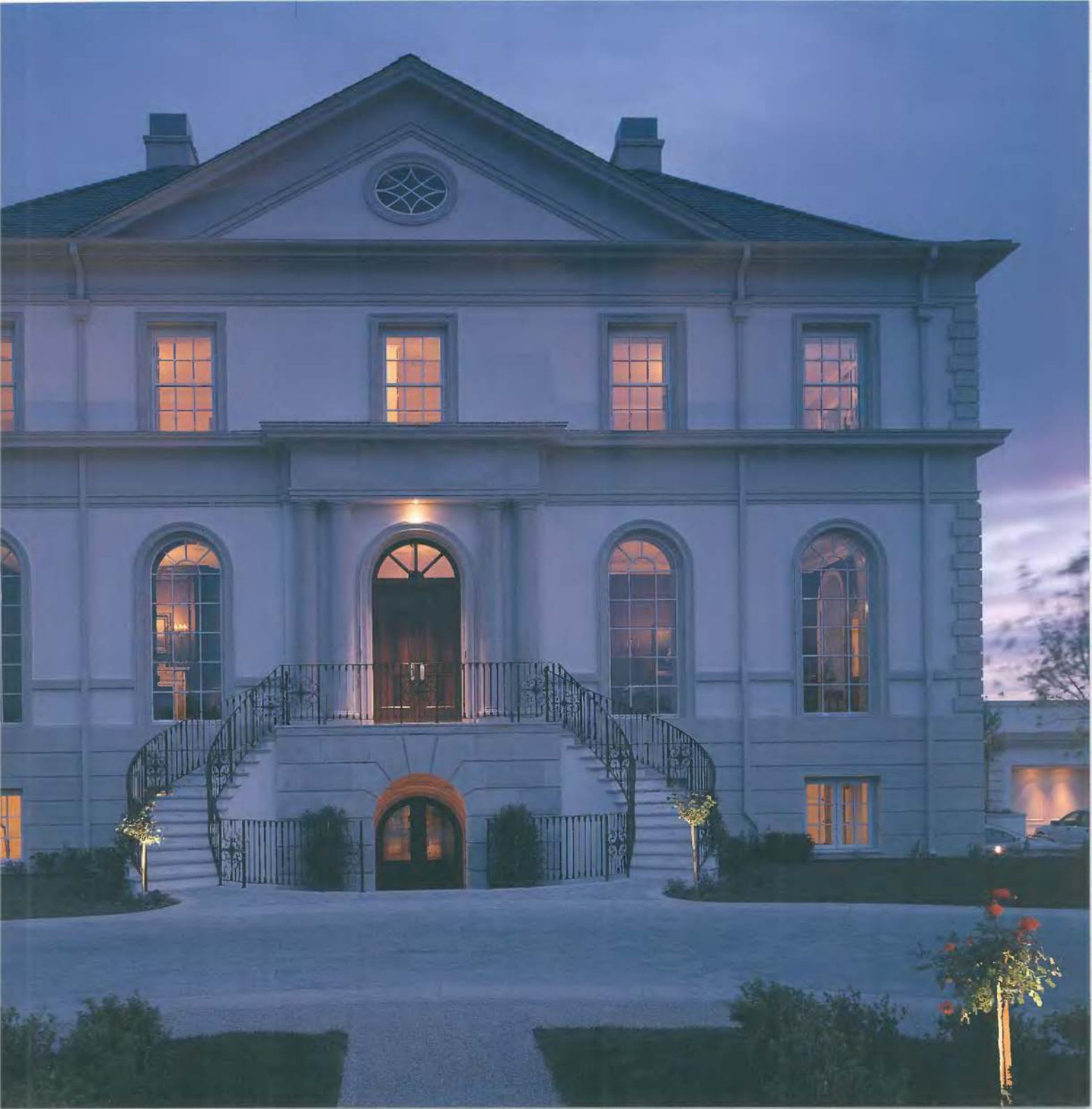







- |               |             |                   |                 |                |
|---------------|-------------|-------------------|-----------------|----------------|
| 1 Foyer       | 6 Kitchen   | 11 Elevator       | 16 Closet       | 21 Balcony     |
| 2 Living Room | 7 Breakfast | 12 Front Terrace  | 17 Upper Hall   | 22 Attic Stair |
| 3 Dining Room | 8 Study     | 13 Master Bedroom | 18 Laundry Room |                |
| 4 Powder Room | 9 Pantry    | 14 Master Bath    | 19 Bedroom      |                |
| 5 Library     | 10 Terrace  | 15 Master Sitting | 20 Bathroom     |                |





















# THE STEVENS HOUSE

Atlanta, Georgia, 2001–2003

*Mark Stevens/Southwick Real Estate, Builder*  
*Interiors by Marilyn Rosenberg*

After a successful career on Wall Street as a bond trader, Mr Stevens retired from the world of finance after his firm was purchased. Having already moved his family to Atlanta when he opened his firm's regional office, he and his wife decided to stay and make Atlanta their home.

"I have always had an interest in building. My summer jobs as a teenager were in residential construction. We remodeled our first home here in Atlanta and I built some speculative homes after I sold my firm. I really enjoy the process," says Mr Stevens. "I became familiar with Bill Baker's work and began working with him on the design of our personal home."

Both Mr Stevens and his wife had grown up in New England homes that were more than 200 years old and still occupied by their respective families. Clearly, they had an appreciation for craftsmanship and well-aged materials, both of which they wanted in their new home.

The design of their home incorporated aged fieldstone, weathered wood shake and a textured wood shake roof. The overall effect is that of a rambling farmhouse in the countryside. But, in fact, the home is located just a few miles from downtown Atlanta on a quiet residential street. The Stevens are an active family with three young children, so the house was designed for both aesthetics and practicality. For instance, the home has a rear service hall with book-bag shelves, a mud bath and locker storage, all perfect for their school-aged children. On the lower level, the home has a media room, game room and second kitchen to provide entertaining space for the children and their friends.

"We wanted this to be the ultimate family home—one that would be comfortable, warm and inviting," says Mr Stevens. "We had the best time building it and look forward to the enjoyment of it in the years ahead."















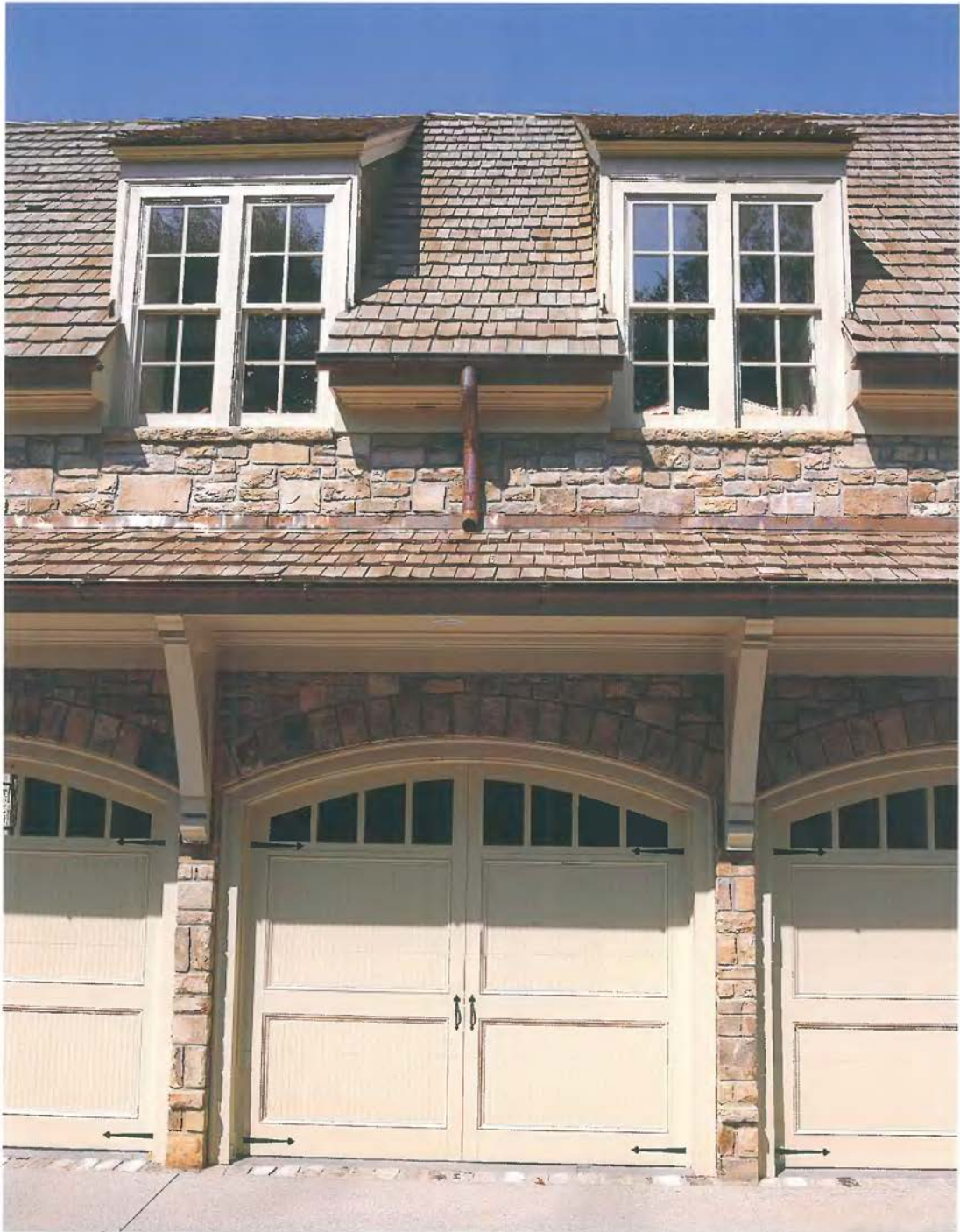



First Floor

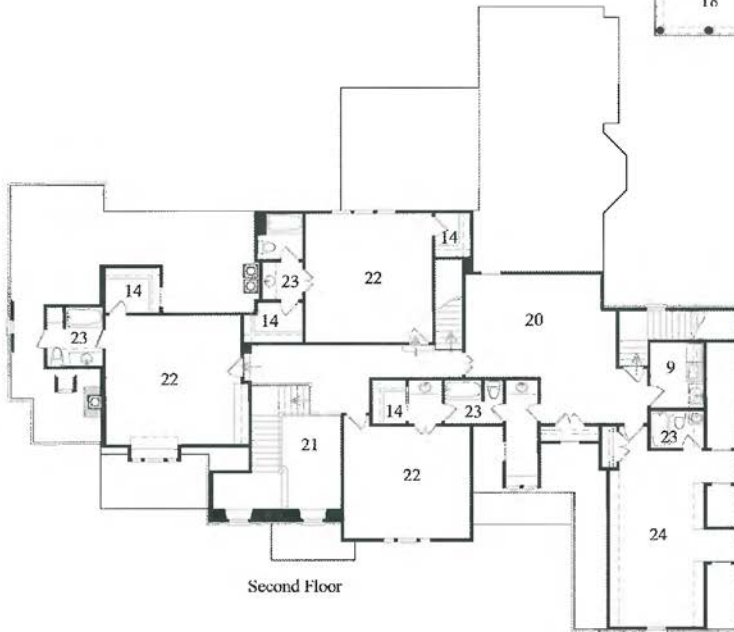

Second Floor

- |                 |                    |                  |                  |                  |
|-----------------|--------------------|------------------|------------------|------------------|
| 1 Foyer         | 6 Kitchen          | 11 Garage        | 16 Pantry        | 21 Open to Below |
| 2 Living Room   | 7 Breakfast        | 12 Master Suite  | 17 Covered Porch | 22 Bedroom       |
| 3 Dining Room   | 8 Keeping Room     | 13 Master Bath   | 18 Open Terrace  | 23 Bath          |
| 4 Powder Room   | 9 Laundry Room     | 14 Closet        | 19 Office        | 24 Bonus Room    |
| 5 Paneled Study | 10 Butler's Pantry | 15 Service Porch | 20 Playroom      |                  |













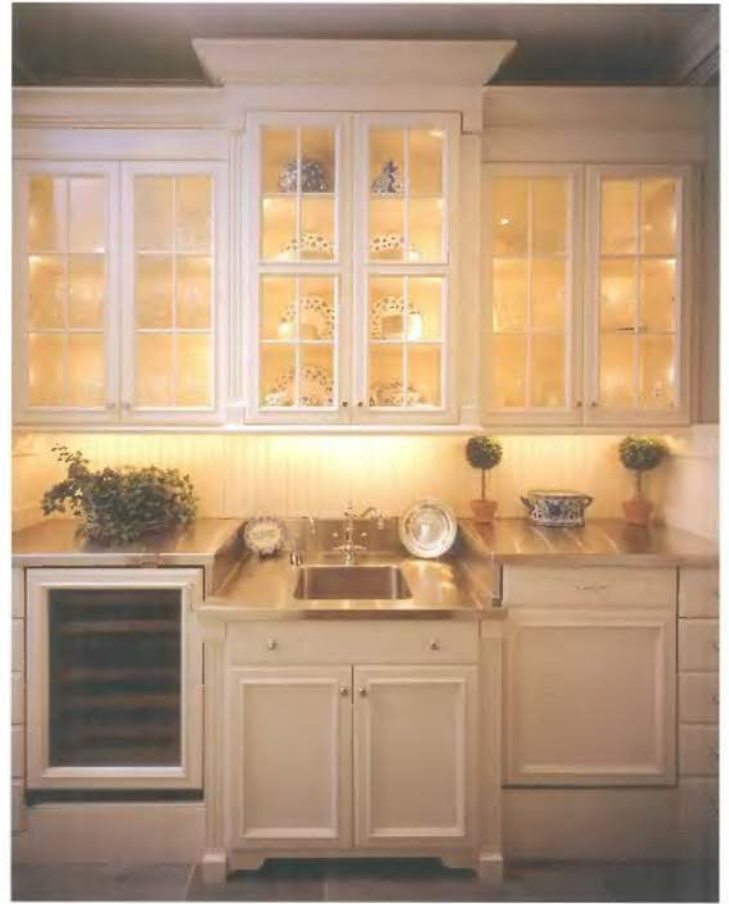



# THE DEGUARDIOLA HOUSE

Atlanta, Georgia, 2000–2003

*Built by the Owner*

*Interiors by Lady Henrietta Spencer-Churchill*

Originally born in Cuba, Mr DeGuardiola came to America with his parents as a young boy in the early 1960s after the Communists came to power. “My parents left everything behind to come to America,” says Mr DeGuardiola. “They believed that we could only thrive as a family in the freedom of this country and were willing to risk everything to start again.” Over the years, through persistent hard work and smart investment decisions, Mr DeGuardiola was able to build a large real estate development company based in Atlanta. Today, that company has interests throughout the Southeastern United States.

In designing their new home, the DeGuardiolas chose as their inspiration the architecture of Robert Adam, an 18th-century Scottish architect known for his classical detailing. “The thing that impressed me the most,” says Mr Baker, “was how quickly they studied and grasped the finer points of Adam’s work. They were a delight to work with because they were so enthusiastic and supportive of my efforts to achieve the look and feel of one of these period houses.”

The house incorporates brick and stone with Corinthian pilasters framing the central bay. The front entry boasts classical design motifs and is the focal point for the handsome façade. The Adam theme is continued throughout the interiors as can be seen in the decorative plaster ceilings, cornices, and in the deeply carved casings and paneling, all expertly installed by Tony Pearson. “We are thrilled with our home,” says Mrs DeGuardiola. “It is a rare success in this day and time to be able to create a home of this quality and detail.”

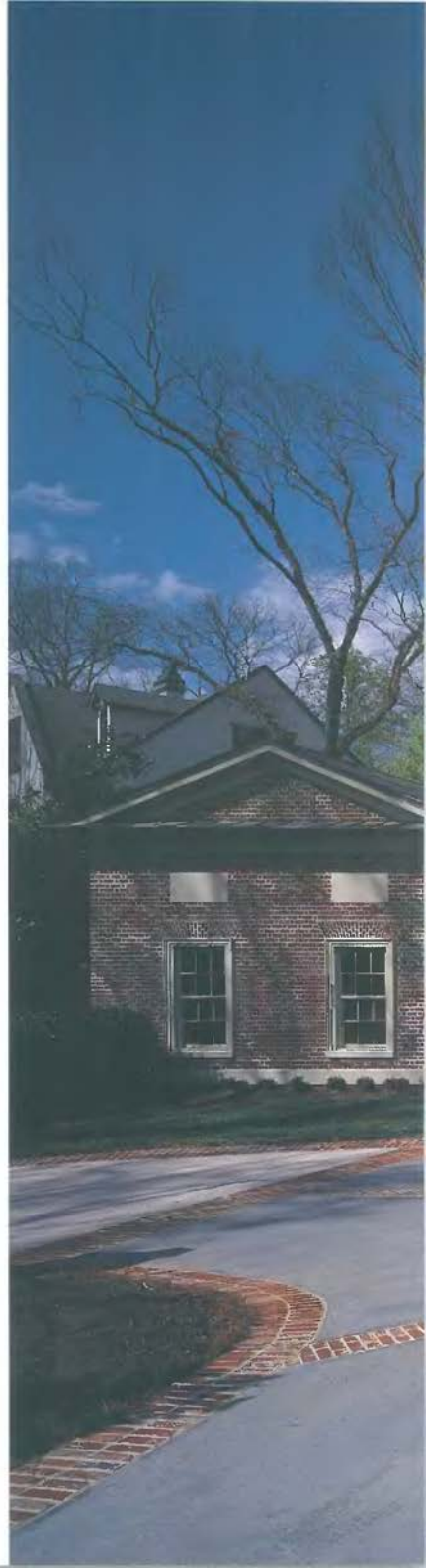











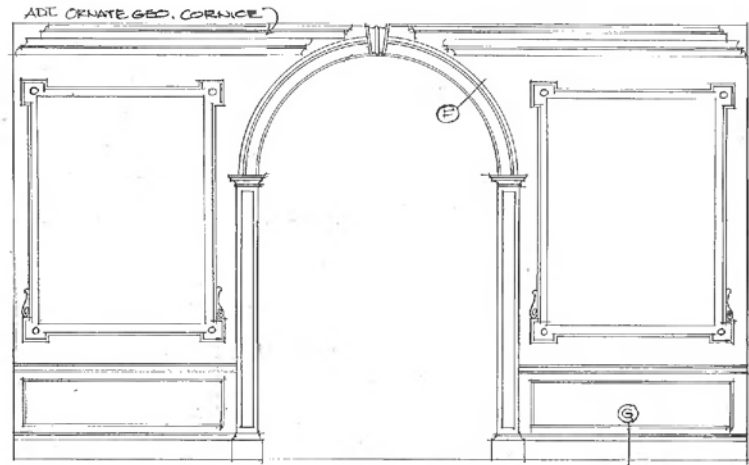
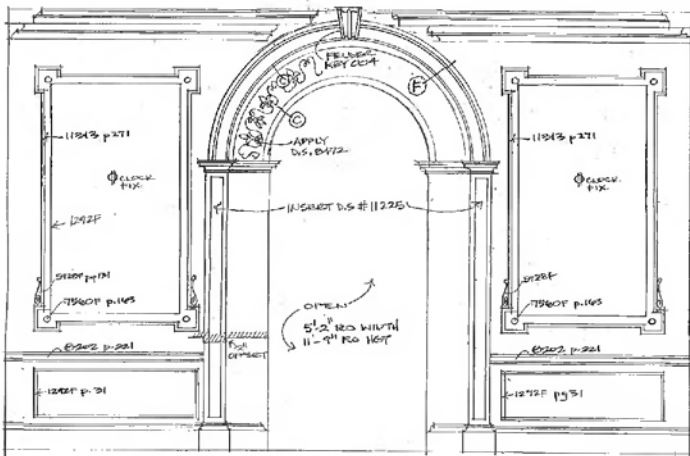
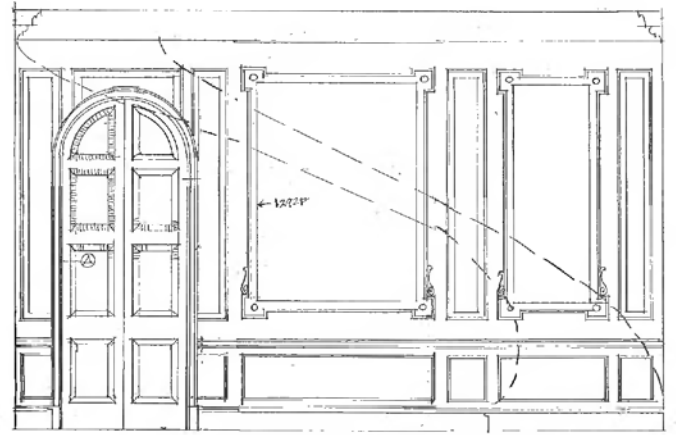
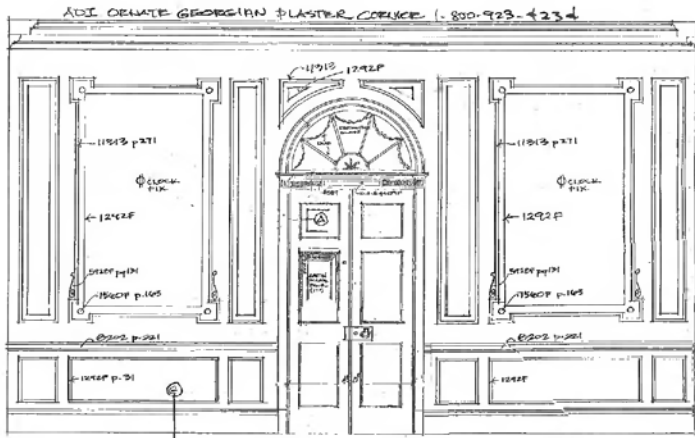





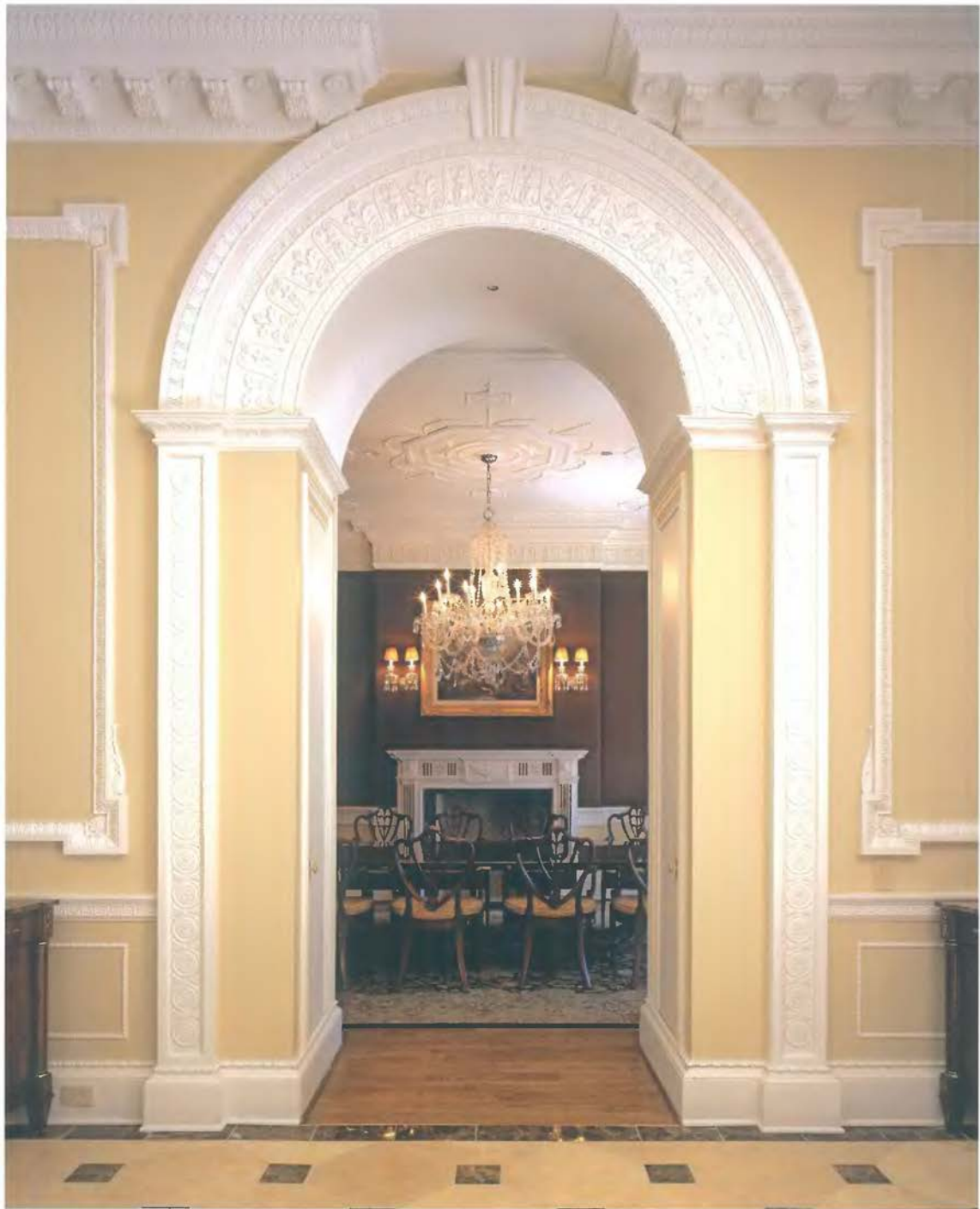

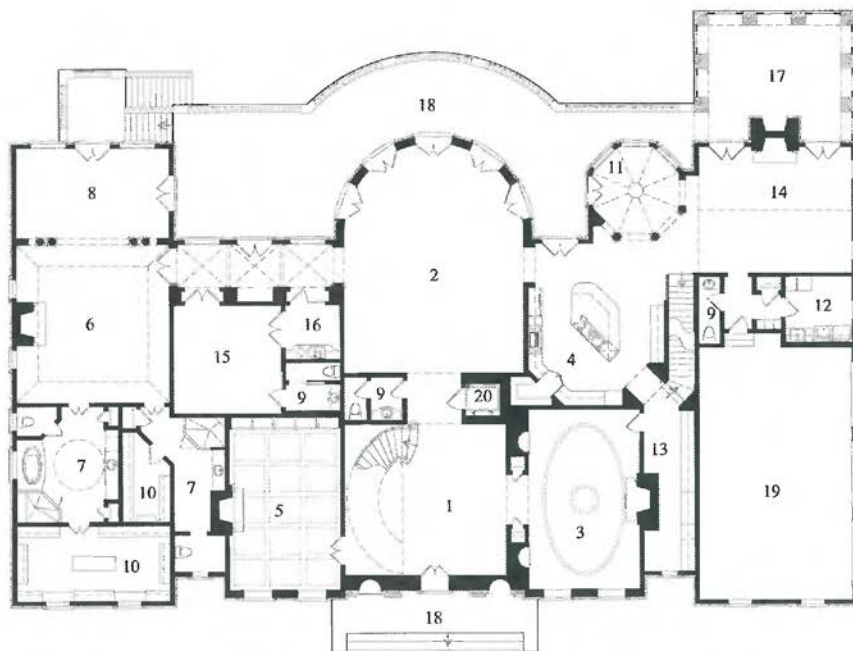

- |               |                |                  |                    |                  |             |                  |
|---------------|----------------|------------------|--------------------|------------------|-------------|------------------|
| 1 Foyer       | 5 Library      | 9 Powder Room    | 13 Butler's Pantry | 17 Covered Porch | 21 Closet   | 25 Sitting Area  |
| 2 Grand Salon | 6 Master Suite | 10 Master Closet | 14 Family Room     | 18 Terrace       | 22 Bedroom  | 26 Open to Below |
| 3 Dining Room | 7 Master Bath  | 11 Breakfast     | 15 Club Room       | 19 Garage        | 23 Bathroom |                  |
| 4 Kitchen     | 8 Sitting Room | 12 Laundry       | 16 Wet Bar         | 20 Elevator      | 24 Playroom |                  |





























# THE AHMAD HOUSE

Dalton, Georgia, 2001–2003

*Darrell Jennings Builder*  
*Interiors by the Owner*

Classicism is usually associated with the architecture of ancient Greece and Rome. This bias toward western architectural design belies the fact that other architectural design motifs have been in use around the world for thousands of years. When considering the architecture of Egypt, China, or the Indian sub-continent, one finds a rich architectural heritage within each of these non-western cultures. The very definition of classicism—that which stands the test of time—should be applied to the architecture of these cultures as well. These nations also have a unique architectural language that has proven its usefulness and enduring popularity for centuries, if not millennia.

While western in style, the Ahmad house incorporates a number of design elements found in the family's cultural homeland of Pakistan. The family collected a number of significant architectural elements which Mr Baker has tastefully incorporated into the fabric of the house. Many of these items—doors, door jambs, columns, and carved panels—are themselves hundreds of years old.

Upon entering the vestibule, one immediately passes through an elaborately carved door and enters the foyer with its paneled ceiling and delicately carved columned screen. At each end of the foyer are antique doors with original strap hinges of forged metal. On the rear terrace, one can see the covered porch with its antique columns and arched screens that open out to the pool.

By creatively incorporating these treasured architectural elements, Mr Baker has given the home a special decorative richness. His sensitive appreciation of that country's heritage of fine craftsmanship in wood and metal has blended old world elements in a new and creative way to create a home for the ages.











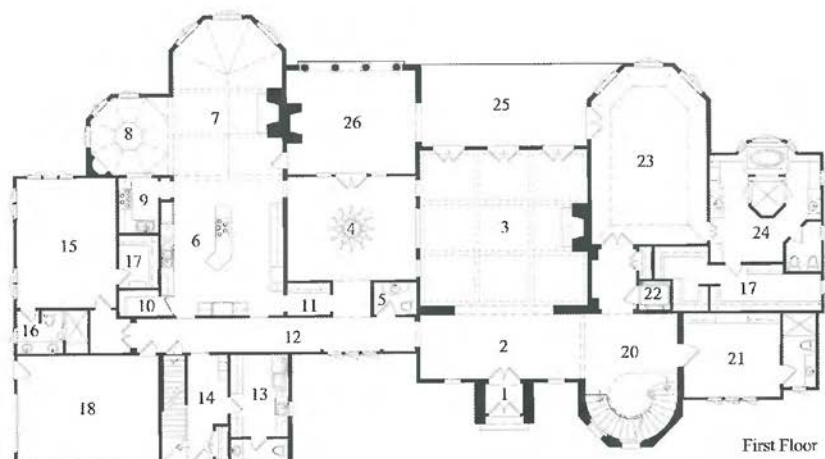

First Floor

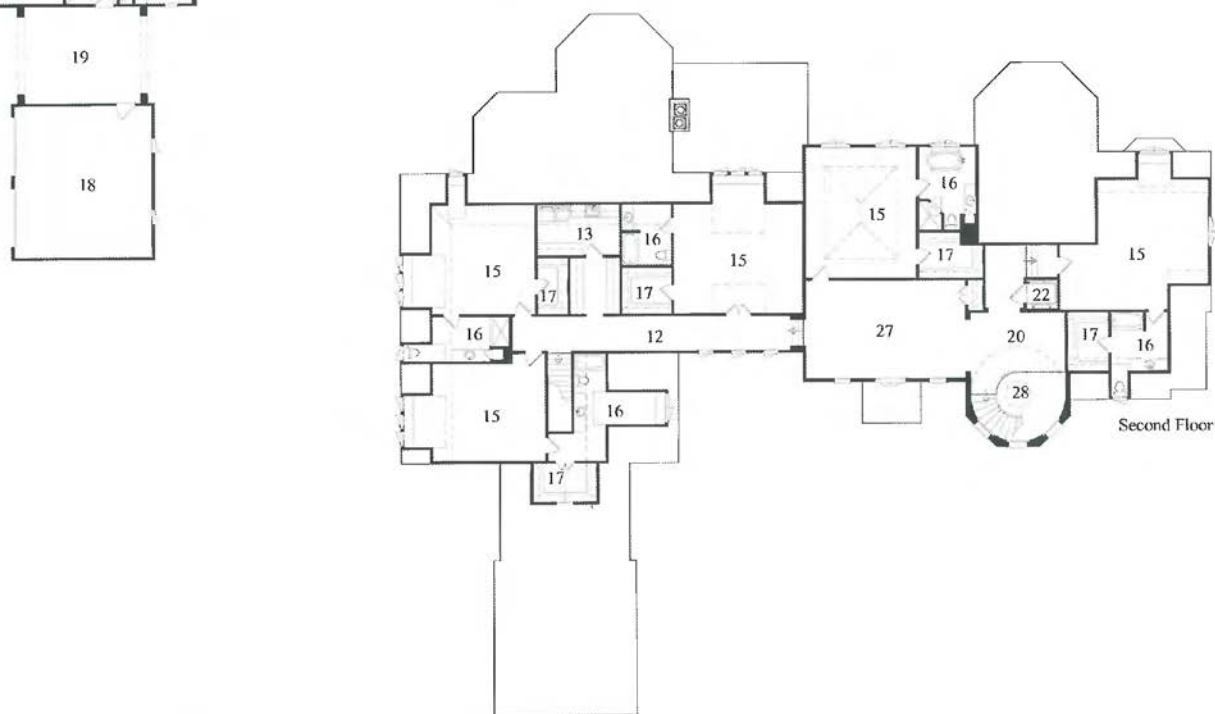

Second Floor

- |               |                     |                    |                  |                   |                  |
|---------------|---------------------|--------------------|------------------|-------------------|------------------|
| 1 Vestibule   | 6 Kitchen           | 11 Butler's Pantry | 16 Bath          | 21 Study          | 26 Covered Porch |
| 2 Foyer       | 7 Keeping Room      | 12 Gallery Hall    | 17 Closet        | 22 Elevator       | 27 Sitting       |
| 3 Living Room | 8 Breakfast         | 13 Laundry         | 18 Garage        | 23 Master Bedroom | 28 Open to Below |
| 4 Dining Room | 9 Caterer's Kitchen | 14 Service Hall    | 19 Porte Cochere | 24 Master Bath    |                  |
| 5 Powder Room | 10 Pantry           | 15 Bedroom         | 20 Stair Hall    | 25 Terrace        |                  |



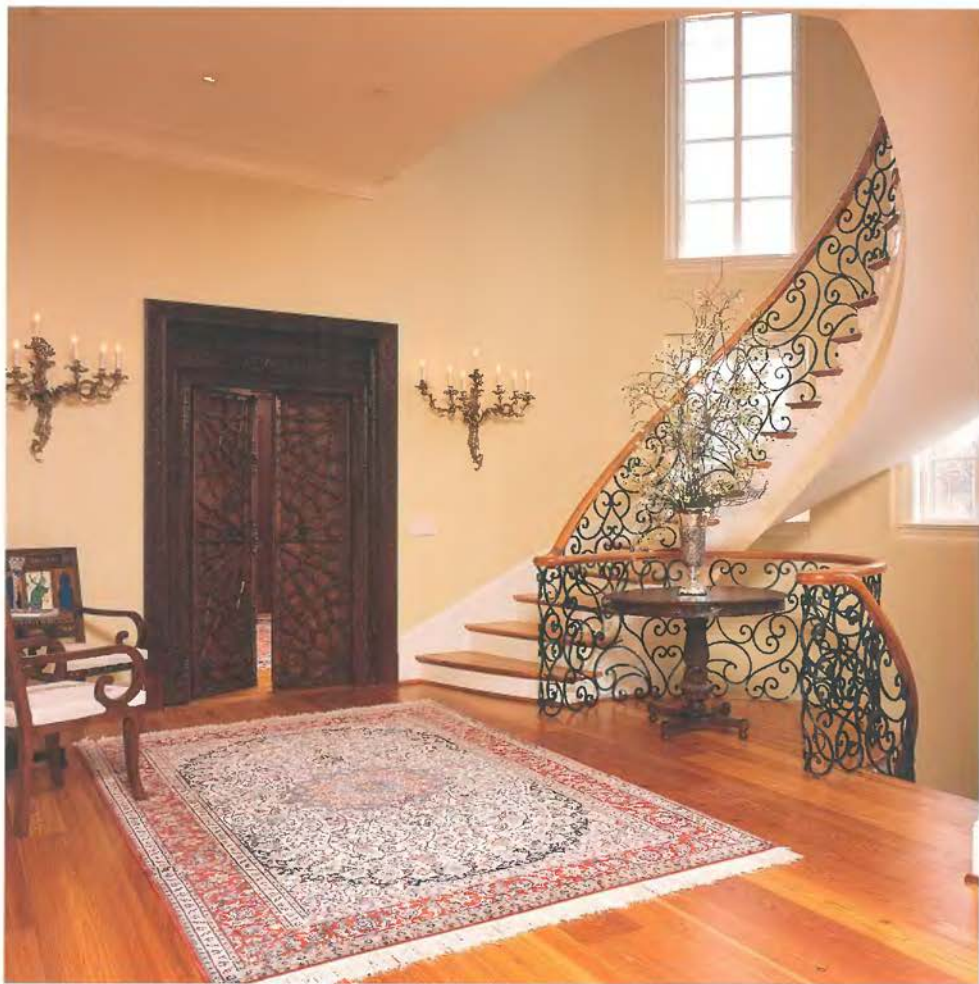





















# THE BERRY HOUSE

Atlanta, Georgia, 2001–2004

*Builders II, Builder*

*Interiors by Suzanne Kasler*

Both Mr and Mrs Berry have their roots in the newspaper business. Mr Berry's first job out of college was working as an advertising salesman for the Atlanta newspaper. He reflects, "When I took the job, I never dreamed I would still be there forty years later." Over the years, Mr Berry would rise through the ranks to be the Publisher and eventually serve as Chief Executive Officer for Cox Enterprises, the newspaper's parent company. Mrs Berry served as Executive Director of the Georgia Press Association for over twenty years.

The Berry's house is located in Druid Hills, a historic Atlanta neighborhood originally laid out by Frederick Law Olmstead. Olmstead, one of America's greatest landscape architects, also designed New York's Central Park and the Biltmore Estate. The neighborhood's focal points are its Olmstead chain of parks bordered by wide tree-lined streets and the Druid Hill Golf Club. The Berry house is located on a quiet street that adjoins the golf course with views of Lullwater Park in front and the golf course with its beautiful fairways at the rear.

The Berrys wanted their home to blend in with those surrounding it, especially the English-style homes from the 1920s. "We love the look of the older homes here but could not find one to buy that suited our needs," says Mrs Berry. "Building a new 'old' house seemed the best thing to do. We knew we had achieved our goal when a passerby asked us how long it had taken us to renovate this old house."

With its hand-carved limestone, heavy variegated slate roof and old-world brick, the Berry house blends seamlessly into its historic neighborhood.

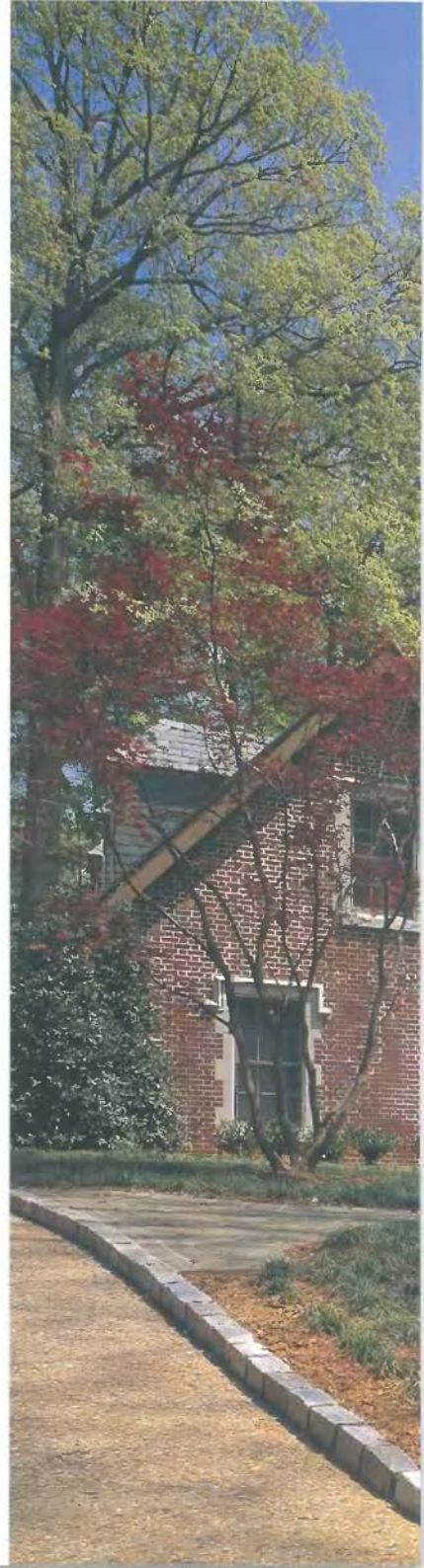









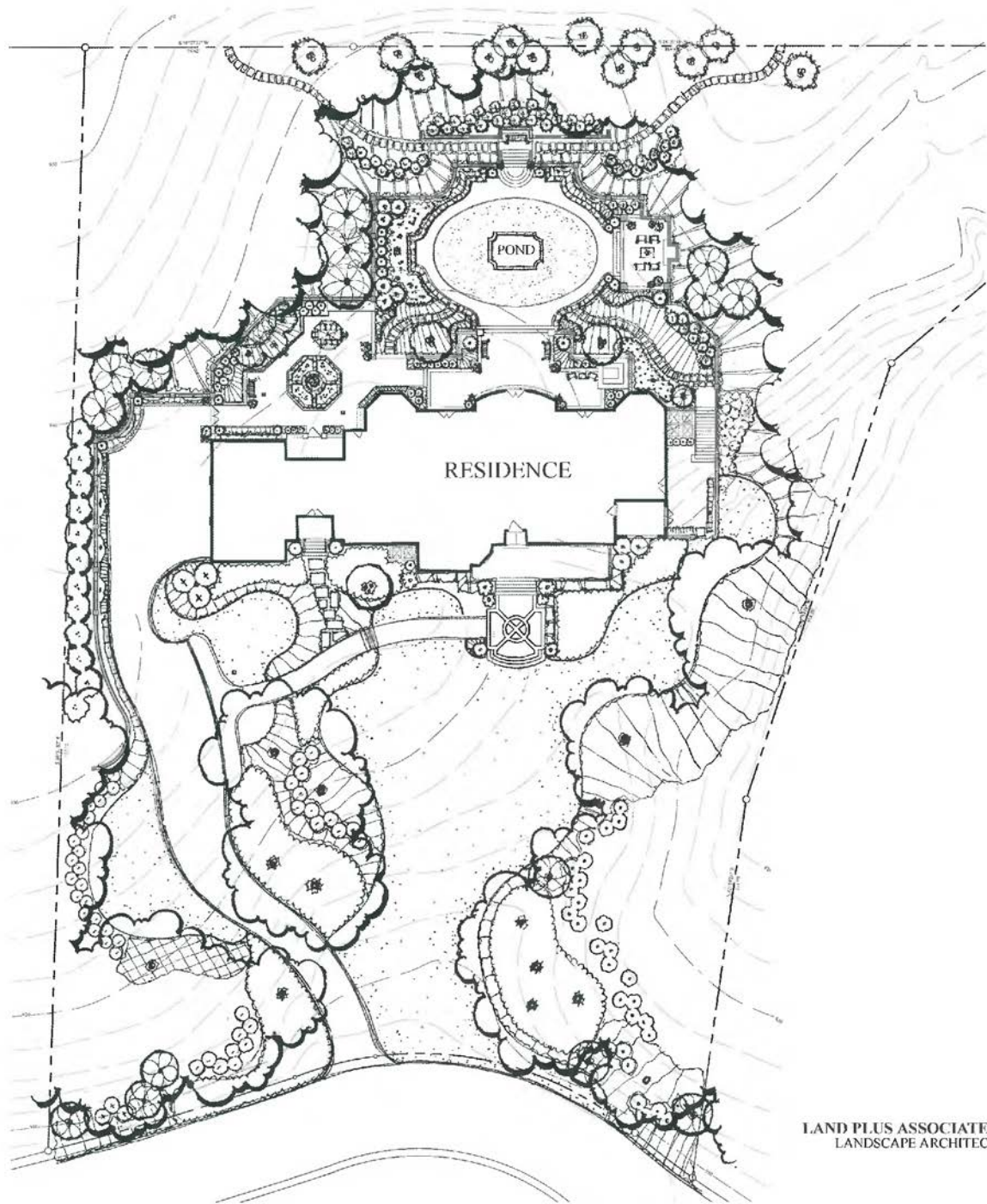

LAND PLUS ASSOCIATES LTD.  
LANDSCAPE ARCHITECTS



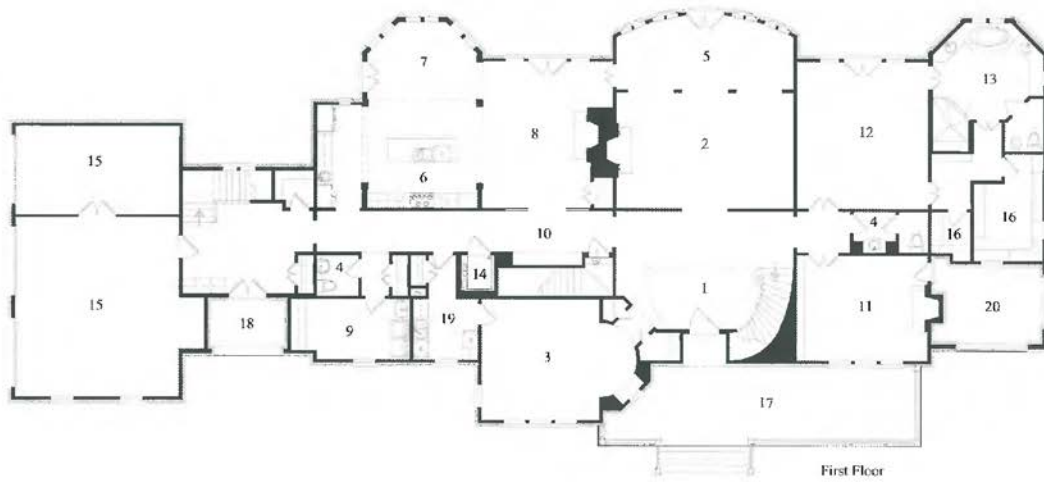

- |               |                |                 |                     |               |                 |
|---------------|----------------|-----------------|---------------------|---------------|-----------------|
| 1 Foyer       | 6 Kitchen      | 11 Library      | 16 Closet           | 21 Bedroom    | 26 Exercise     |
| 2 Living Room | 7 Breakfast    | 12 Master Suite | 17 Front Terrace    | 22 Bath       | 27 Open Terrace |
| 3 Dining Room | 8 Family Room  | 13 Master Bath  | 18 Service Entrance | 23 Media Room | 28 Storage      |
| 4 Powder Room | 9 Laundry Room | 14 Elevator     | 19 Butler's Pantry  | 24 linen      |                 |
| 5 Sun Room    | 10 Gallery     | 15 Garage       | 20 Covered Porch    | 25 Upper Hall |                 |











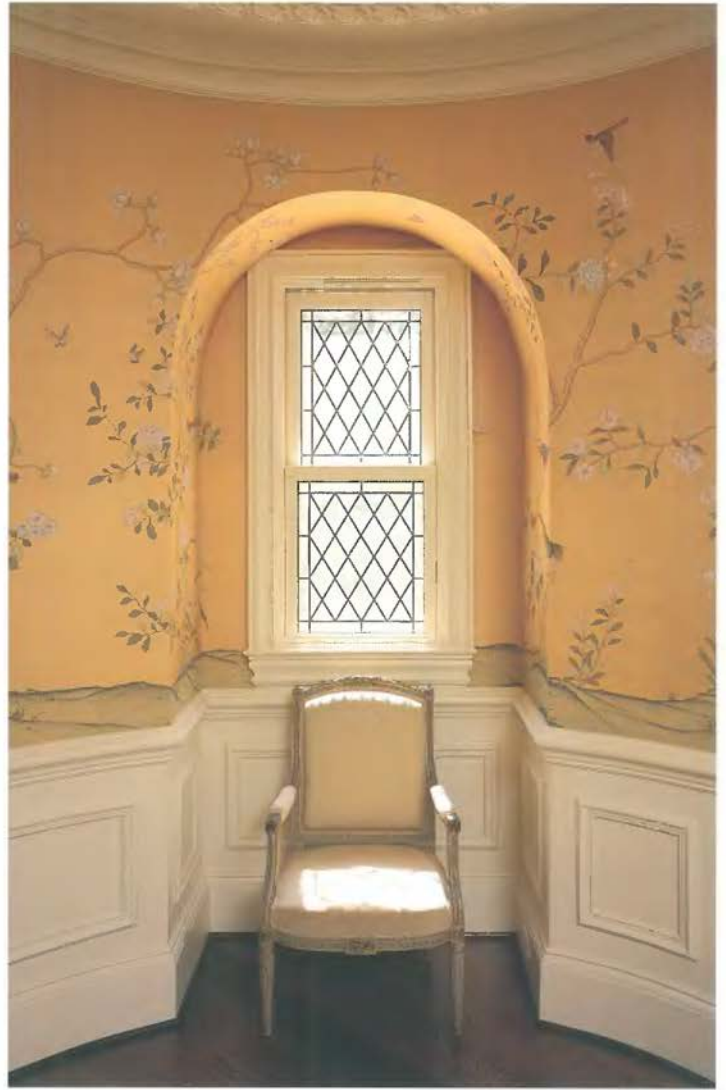





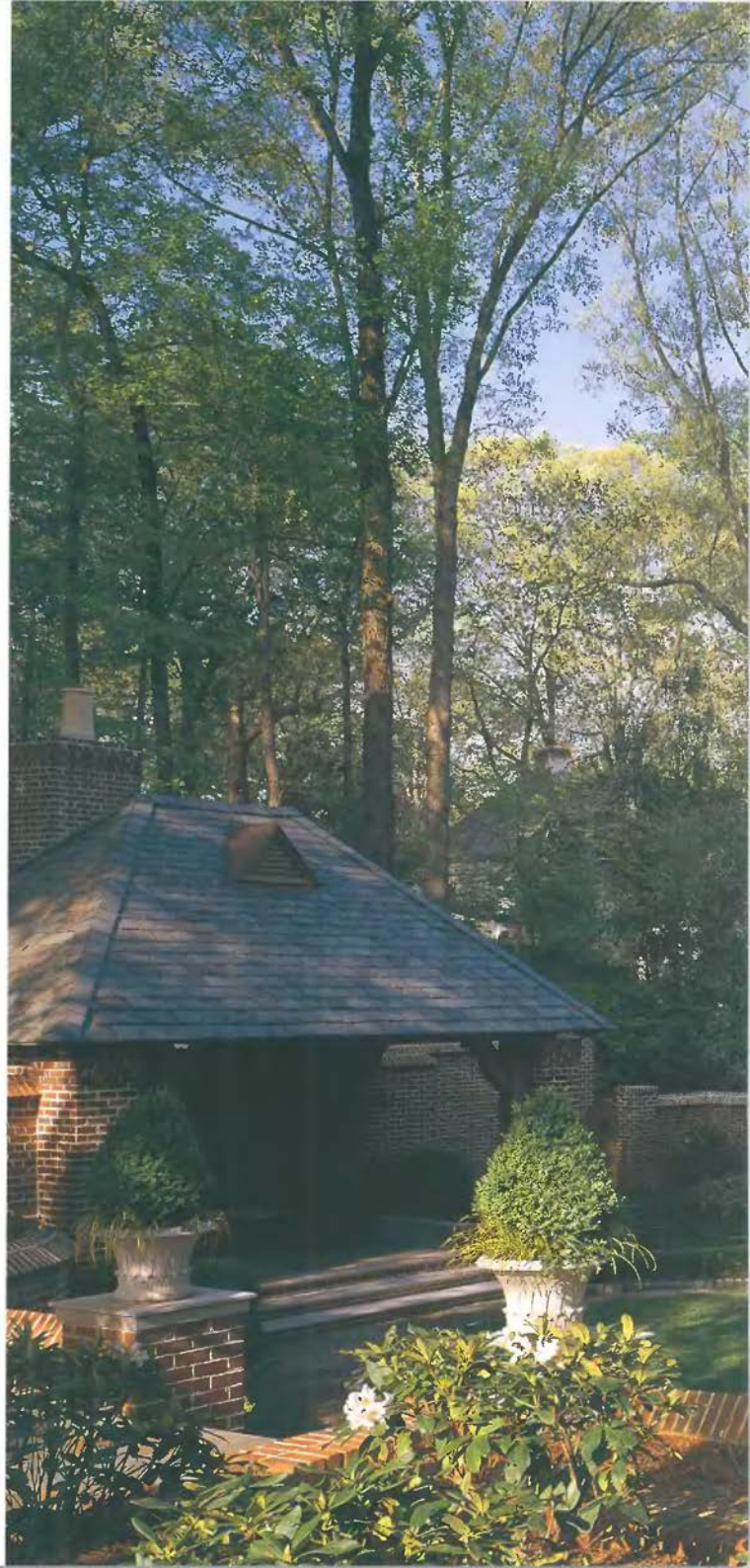







# THE WINSTON

Atlanta, Georgia, 1998–2000

*Developed by Gene Hall and Billy Ivey  
Designed in collaboration with CDH Partners*

Market timing is often the difference between success and failure. In the case of The Winston, Mr Hall and Mr Ivey had excellent timing. Soon after the Centennial Olympic Games left Atlanta in 1996, they saw that the inventory of luxury condominiums was depleted in northwest Atlanta. They acquired a choice piece of land on Peachtree Street that had a view of the Atlanta skyline and was located one block from the shopping of Phipps Plaza and Lenox Mall. With the design talent of Mr Baker, they constructed a 36-unit high rise that was one of the first of its kind on the Atlanta market. The building sold well. Other developers followed their lead and soon many similar projects were launched. However, by the time The Winston was sold out, the market had become saturated and some of the other projects languished.

Inspired by the luxury apartment buildings of pre-1940s New York, Mr Baker incorporated a rusticated stone base with traditional red brick and classic double-hung windows. The mortar color was carefully chosen to complement the stone. Behind the building is a quiet garden sheltered from the noise and commotion of Peachtree Street.

Each condominium was designed as a corner unit, giving it two exposures, generous light, and excellent views. The units range in size from 1,850 to 6,000 square feet. The building includes an indoor lap pool, a fully equipped exercise room, and 24-hour concierge services. "We were so pleased with the building that Mr Ivey and I both purchased units in the Winston for our personal residences," remarks Mr Hall. "It has been a landmark building from its beginning."

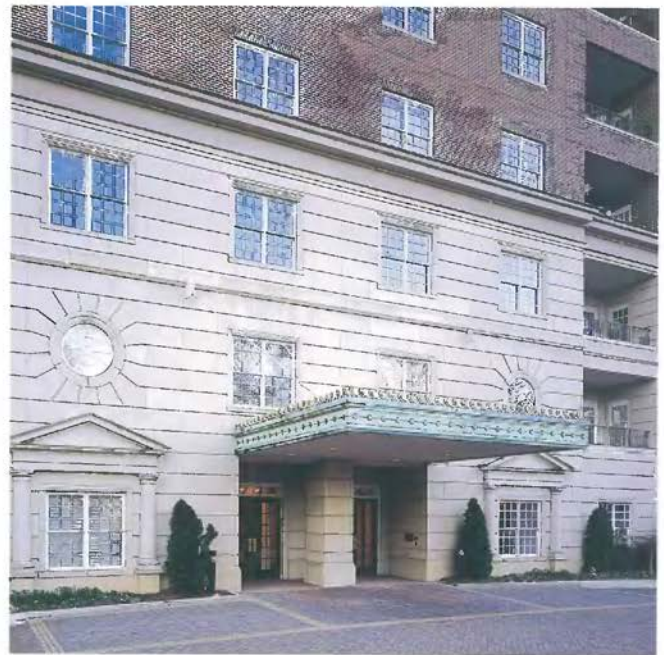



- 1 Foyer
- 2 Living Room
- 3 Dining Room
- 4 Kitchen
- 5 Gallery
- 6 Master Suite
- 7 Master Bath
- 8 Powder Room

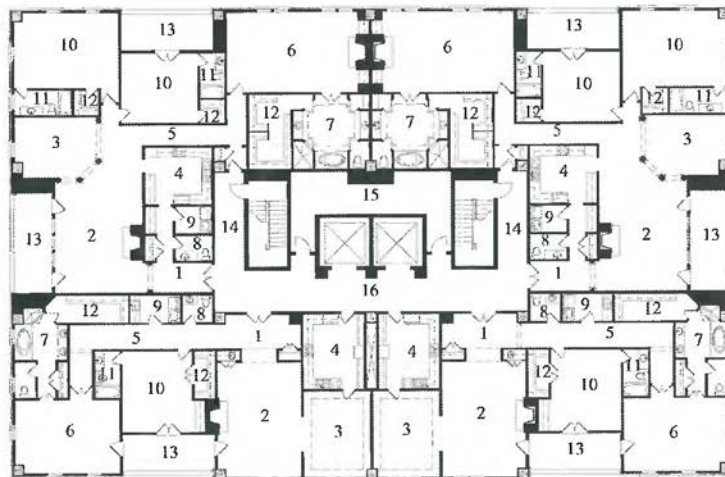

- 9 Laundry Room
- 10 Bedroom
- 11 Bath
- 12 Closet
- 13 Balcony
- 14 Hall
- 15 Mechanical
- 16 Elevator Lobby









# THE CRESCENT AT POST RIVERSIDE

Atlanta, Georgia, 1999–2001

*Post Properties, Contractor*

The Crescent at Post Riverside is a new luxury town home community designed in the spirit of Regency England. Mr Baker derived the crescent shape of the five town homes from the classic architecture of Bath, England. His selection of materials and details was inspired by the American architecture of Thomas Jefferson. Each home's entryway was made unique, reflecting a different detail from Jefferson's work at the University of Virginia.

Each door's leaded transom was based on an 18th-century model. Following Mr Baker's design, Atlanta's Vloeberghs Studio used restoration glass and hand-cast lead fittings to produce the unique transoms. The interiors, with their 12-foot ceilings, are gracefully proportioned and have interior trim moldings typical of homes of the period.

The typical unit is 3,800 square feet, with two floors above a full basement that contains secured private parking for each unit. Mr Baker designed each home with a private elevator that connects all three levels. Because the Crescent adjoins the Chattahoochee Nature Preserve, the rear terraces of each home have a pleasant view of the dense woods, which are bordered by the Chattahoochee River.









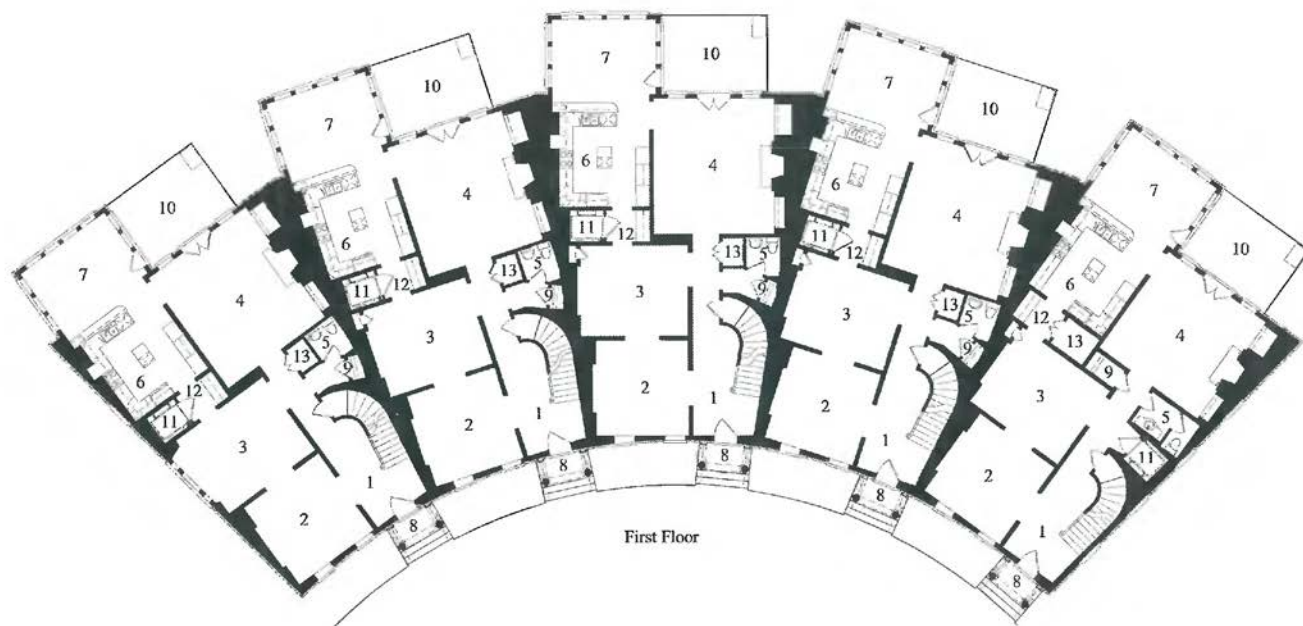
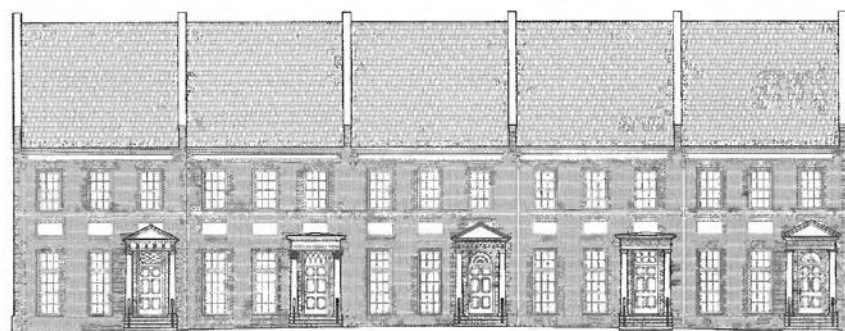

- |               |               |                    |
|---------------|---------------|--------------------|
| 1 Foyer       | 6 Kitchen     | 11 Elevator        |
| 2 Living Room | 7 Breakfast   | 12 Butler's Pantry |
| 3 Dining Room | 8 Front Porch | 13 Mechanical      |
| 4 Family Room | 9 Closet      |                    |
| 5 Powder Room | 10 Terrace    |                    |









# THE BORGHESE

Atlanta, Georgia, 1999–2001

*Developed by Southeast Capital Partners*

*Construction by Hardin Construction and Cambridge Builders, Inc.*

*Designed in partnership with Cecil Alexander FALA and Irv Weiner AIA and in collaboration with Leo Daly Architects*

The Borghese is a 57-unit luxury condominium community in the heart of Atlanta's most prestigious neighborhood. The building features four sizes of units ranging from 1,600 to 3,950 square feet with two penthouses of over 4,000 square feet. The use of classical detailing, such as Venetian arches, classical balustrades, and rustication distinguish it among the city's many attractive luxury condominiums. With its curved walls, bowed front balconies and tower elements, the building presents an interesting profile against the sky.

The Borghese offers 24-hour concierge service, a full spa and private health club with heated outdoor pool, a classical garden with fountains, and the Intermezzo Club Room with catering facilities for private entertaining. In addition to the Borghese's in-house amenities, residents can enjoy gourmet dining at Joel's restaurant, on-site banking, dry cleaning services, car detailing, and a sundries shop in the adjoining building located just across the formal garden.

"It was indeed an honor for me to have partnered with Mr Alexander and Mr Weiner on this project," says Mr Baker. "They are both icons in the Atlanta architecture community and I am privileged to have worked with them."









Northside Parkway Elevation

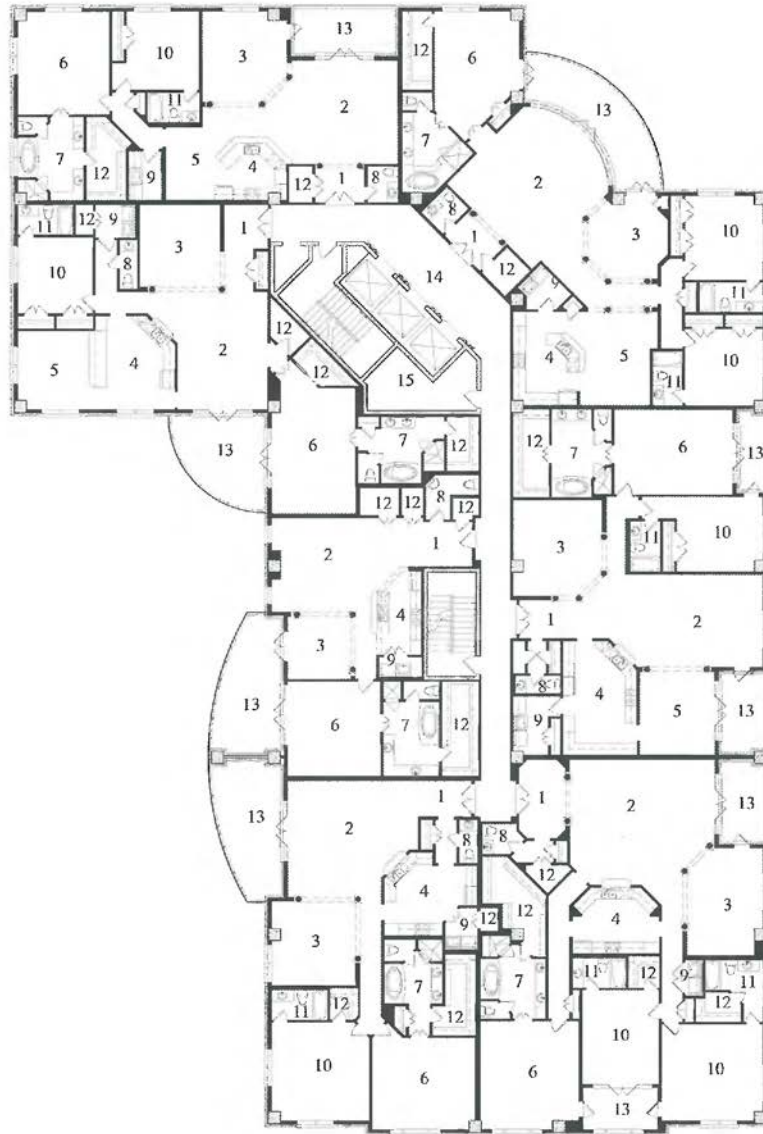

- |               |                |                |                   |
|---------------|----------------|----------------|-------------------|
| 1 Foyer       | 5 Breakfast    | 9 Laundry Room | 13 Balcony        |
| 2 Living Room | 6 Master Suite | 10 Bedroom     | 14 Elevator Lobby |
| 3 Dining Room | 7 Master Bath  | 11 Bath        | 15 Mechanical     |
| 4 Kitchen     | 8 Powder Room  | 12 Closet      |                   |











# ACKNOWLEDGEMENTS

The completion of any book requires special appreciation of the many people who made it possible. When that book covers 20 years of one's career, it seems the number of people to thank is multiplied even further. To begin, I wish to thank my father, who inspired my love of drawing, and to my mother, whose love and emotional support gave me the inner courage to take risks and pursue my dreams. I am grateful to my wife, whose encouragement and excitement made producing this book a real pleasure. And most importantly, I thank God for giving me the talent and the opportunity to use that talent, which has made this book possible.

As a great architect once said, 'An architect is only as good as his clients,' and that still holds true today. This book has been made possible by the many families who entrusted me with their dreams and allowed me to turn them into a reality. It has been an honor, and to each of them, I say a grateful thank you.

On a professional note, I have several people to thank. I am indebted to my associates, Aubrey Stringer and Ty Smith, who have worked so hard to produce the plans by which these dreams were made. I am also grateful to the builders and craftsman who so skillfully executed those plans. Thanks to them, pen and paper became stone and mortar. I also wish to thank the many interior designers and landscape architects whose talented work completed my architecture and made these homes beautiful spaces in which to live.

My appreciation also goes to my photographer, James Lockhart, who so skillfully captured each home's special essence. I also wish to thank Paul Latham and Alessina Brooks of The Images Publishing Group, who so graciously invited me to be a part of this wonderful architecture series.

And finally, I offer many thanks to Beverly M. DuBose III for his years of friendship and support, and for sharing his great knowledge of architecture in his introduction to this book.



Every effort has been made to trace the original source of copyright material contained in this book.  
The publishers would be pleased to hear from copyright holders to rectify any error or omissions.

The information and illustrations in this publication have been prepared and supplied by William T. Baker. While all reasonable efforts have been made to ensure accuracy, the publishers do not, under any circumstances, accept responsibility for errors, omissions and representations express or implied.

Other titles in the *New Classicists* series from  
The Images Publishing Group

**Ken Tate Architect**  
**Selected Houses Volume One**

ISBN 1 864701 01 3

This collection of houses illustrates a splendid diversity of stylistic approaches to classical architecture and the range of creative possibilities within this architectural specialty. American architect Ken Tate's personal interpretation of classical conventions, his meticulous detailing, and his close affinity with his clients, allow each home to stand apart as an individual work of art—beautiful, livable, and engaging.

**Ken Tate Architect**  
**Selected Houses Volume Two**

ISBN 1 920744 43 6

Following the success of Ken Tate's first book, this volume presents a further collection of beautiful homes. Tate's designs spring from impeccable research, a deep understanding of his clients' wishes and the locales in which they have chosen to build. All the homes presented in this second volume owe their grace and beauty to Tate's impressive knowledge of the classical tradition.

**Robert Adam Architects Ltd**  
ISBN 1 920744 54 1

This important addition to the *New Classicists* series features the work of Robert Adam Architects Ltd, a firm with an international reputation in classical and traditional architecture and design. The practice is a world leader in progressive classical design, combining tradition with the latest technology. A broad portfolio of work includes town and country houses, housing developments, urban masterplans, commercial development and public buildings.

**Appleton & Associates Inc. – Architects**  
ISBN 1 920744 60 6

This superb book features the design work of Appleton & Associates Inc., a Californian firm always inspired by and responsive to its clients' specific desires, needs, program and budget. A harmonious relationship between the buildings and landscape is always an essential concern. The firm's work frequently draws upon the time-honored traditions of vernacular architecture, subtly reinterpreting them to evoke a presence of the past.





ISBN 1 920744 57-6



90000



9 781920 744571